

INSTALLATION MANUAL

COLOR GPS/PLOTTER

GP-1650/1650D

Equipment Lists	i
System Configuration	1
1. Installation of Standard Equipment	2
1.1 Installation of Display Unit	2
1.2 Installation of Antenna Unit	4
2. Wiring	5
3. Initial Settings	8
3.1 NMEA Setting	8
3.2 Output Data Sentences	10
3.3 Antenna Height	11
3.4 Baud Rate Setting (GP-1650D only)	12
3.5 Beacon frequency Setting (GP-1650D only)	13
4. Installation of DGPS Beacon Receiver (for GP-1650)	14
PACKING LIST	A-1
OUTLINE DRAWINGS	D-1
INTERCONNECTION DIAGRAM	S-1
SCHEMATIC DIAGRAM	S-2



© **FURUNO ELECTRIC CO., LTD.**

9-52 Ashihara-cho,
Nishinomiya, Japan

Telephone : 0798-65-2111

Telefax : 0798-65-4200

Your Local Agent/Dealer

All rights reserved.

Printed in Japan

PUB.No. IME-43940-M

(TATA) GP-1650/1650D

FIRST EDITION : NOV. 1998

M : FEB. 06,2002



* 0 0 0 8 0 8 5 6 5 0 1 *



* I M E 4 3 9 4 0 M 0 0 *



SAFETY INSTRUCTIONS

Safety Instructions for the Installer



WARNING



Do not work inside the equipment unless totally familiar with electrical circuits.

Hazardous voltage which can shock, burn or cause serious injury exists inside the equipment.



Turn off the power at the mains switchboard before beginning the installation. Post a sign near the switch to indicate it should not be turned on while the equipment is being installed.

Fire, electrical shock or serious injury can result if the power is left on or is applied while the equipment is being installed.



CAUTION



Ground the equipment to prevent electrical shock and mutual interference.

Confirm that the power supply voltage is compatible with the voltage rating of the equipment.

Connection to the wrong power supply can cause fire or equipment damage. The voltage rating appears on the label at the rear of the display unit.

Use the correct fuse.

Use of a wrong fuse can cause fire or equipment damage.

Keep the following compass safe distance.

	Standard	Steering
Display Unit	0.82 m	0.62 m

A warning label is attached to the equipment. Do not remove the label. If the label is missing or illegible, contact a FURUNO agent or dealer.

WARNING

To avoid electrical shock, do not remove cover. No user-serviceable parts inside.

警告

感電の恐れあり。
サービスマン以外の方はカバーを開けないで下さい。内部には高電圧部分が多い数多くあり、万一さわると危険です。

Name: Warning Label (1)
Type: 86-003-1011-0
Code No.: 100-236-230

Equipment Lists

Standard supply

No.	Name	Type	Code No.	Qty	Remarks
1	Display Unit	GP-1650	-	1	
		GP-1650D	-		
2	Antenna Unit	GPA-017	-	1	for GP-1650
		GPA-018	-		for GP-1650D
		GPA-019	-		for GP-1650D
3	Spare Parts	SP14-02401	004-374-630	1	
4	Installation Materials	CP14-05100	000-041480	1	
5	Accessories	FP14-02301	004-375-830	1	Haed cover
		FP14-02302	004-375-850	1	screws for hanger, screws for flush mount

Optional equipment

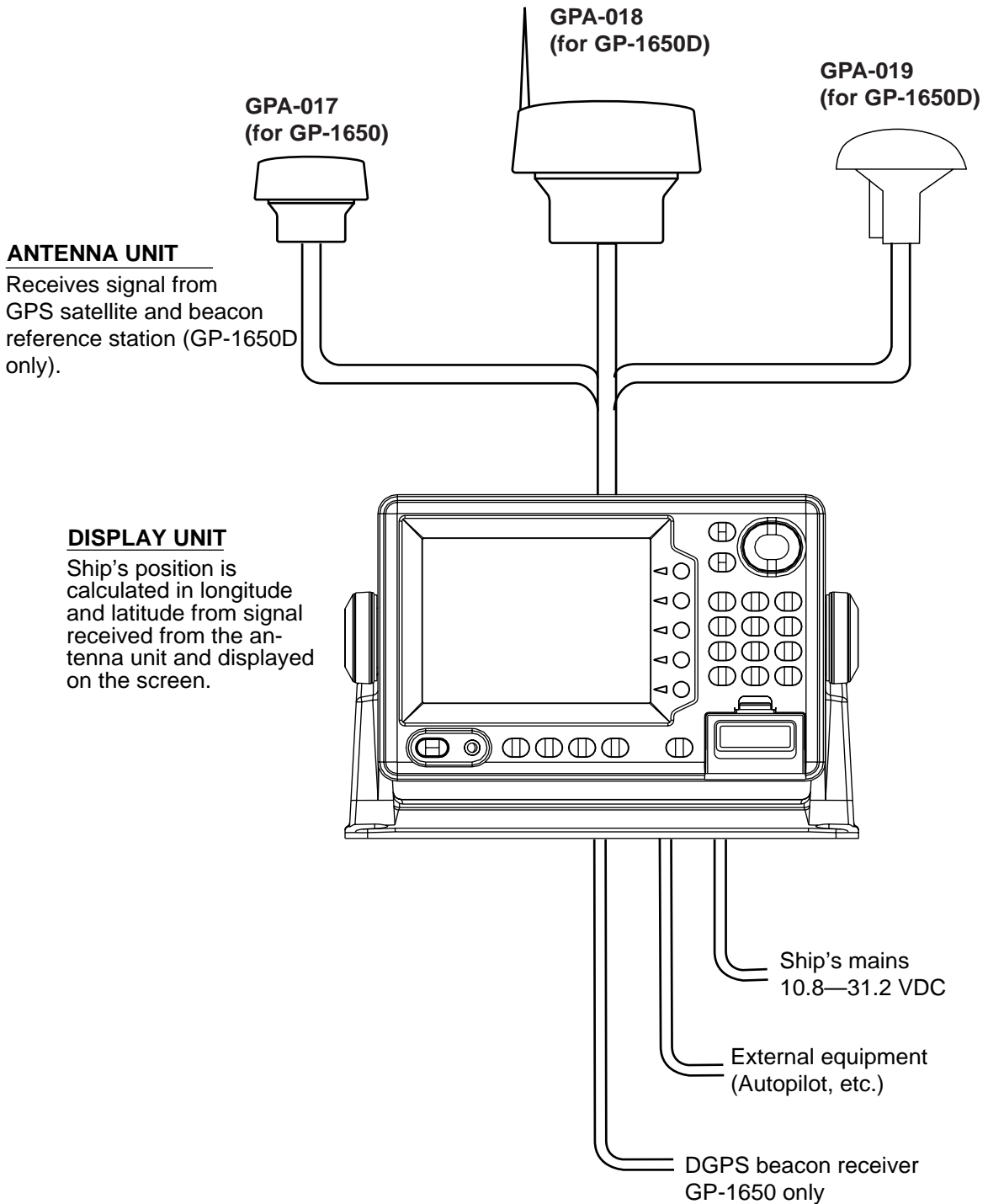
No.	Name	Type	Code No.	Remarks
1	Beacon Receiver Kit	GR-802-1650-10A-018	000-041-651	GPA-018, GR-7000A, whip ant.
		GR-802-1650-10N-018	000-041-482	GPA-018, GR-7000A
		GR-802-1650-15A-018	000-041-652	GPA-018S, GR-7000A, TBC-PS-3D-15, whip ant.
		GR-802-1650-15N-018S	000-041-483	GPA-018S, TNC-PS-3D-15, GR-7000A
		GR-802-1650-10N-019	000-041-650	GPA-019, GR-7000A
		GR-802-1650-15N-019S	000-041-653	GPA-019S, GR-7000A
2	Antenna cable assy.	TNC-PS-3D-15	000-133-670	15m, for antenna cable extension
3	Antenna cable Set	CP20-01700	004-372-110	30m, for antenna cable extension
		CP20-01710	004-372-120	50m, for antenna cable extension
4	Cable Assy.	MJ-A7SPF0003-050	000-136-730-01	
5	Mast mount fixture	CP20-0111	004-365-780	
6	Right-angle antenna base	No. 13-QA330	000-803-239	for mounting antenna unit
7	L-angle antenna base	No. 13-QA310	000-803-240	
8	Antenna base for rail mounting	No. 13-RC5160	000-806-114	

Optional equipment (con't)

No.	Name	Type	Code No.	Remarks
9	Antenna Unit	GPA-018S	000-041-462	For GP-1650D
		GPA-016	000-041-536	For GP-1650
		GPA-019S	000-041-554	For GP-1650D
10	DGPS Beacon Receiver	GR-80	-	For GP-1650
11	Rectifier	PR-62 2.5GY5/1.5NT#5	000-013-484	AC100V
		PR-62 2.5GY5/1.5NT#5	000-013-485	AC110V
		PR-62 2.5GY5/1.5NT#5	000-013-486	AC220V
		PR-62 2.5GY5/1.5NT#5	000-013-487	AC230V
12	Cable Assy.	MJ-A6SPF0007-100	000-125-237	For GPA-018/018S
13	Whip Antenna	FAW-1.2	000-130-046	
14	RAM Card	00RAM02MC-004	004-371-790	2MB

System Configuration

The GP-1650/1650D mainly consists of a display unit and a GPS antenna. A DGPS beacon receiver is provided inside the display unit for GP-1650D type. The chart card drive in the display unit loads electronic charts. External equipment which may be connected include an autopilot and a DGPS beacon receiver.



1. Installation of Standard Equipment

1.1 Installation of Display Unit

Mounting considerations

The display unit can be installed on a tabletop, on the overhead or flush mounted in a console or panel.

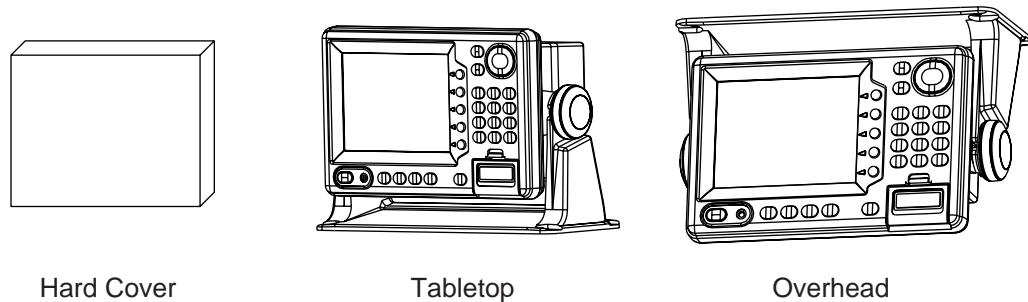


Figure 1-1 Tabletop, overhead mounting methods

When selecting a mounting location for the display unit keep the following in mind:

- Keep the display unit out of direct sunlight.
- The temperature and humidity should be moderate and stable.
- Locate the unit away from exhaust pipes and vents.
- The mounting location should be well ventilated.
- Mount the unit where shock and vibration are minimal.
- Keep the unit away electromagnetic field generating equipment such as motor, generator.
- For maintenance and checking purposes, leave sufficient space at the sides and rear of the unit and leave slack in cables.
- A magnetic compass will be affected if placed too close to the display unit. Observe the following compass safe distances to prevent disturbance to the magnetic compass:

Standard compass: 0.82 meters

Steering compass: 0.62 meters

Mounting procedure

Follow the procedure below to mount the display unit on a tabletop or the overhead.

Tabletop, overhead mounting

1. Fix the hanger by four pan head screws M5 X 16.
2. Screw knob bolts in display unit, set it to hanger, and tighten knob bolts.
3. Attach hard cover to protect LCD.

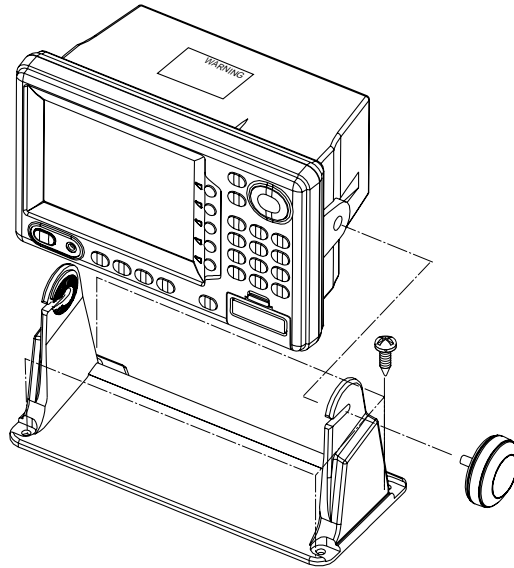
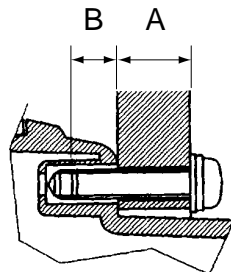


Figure 1-2 Tabletop, overhead mounting of display unit

Flush mounting

Note: Use supplied pan head screws when the thickness of the bulkhead is from 11 to 14 mm. For bulkhead which exceeds 14 mm in thickness the length of the pan head screws should be bulkhead thickness+7.8±1.5 mm. Also the length of B should max. 8mm.



1. Prepare a cutout in the mounting location whose dimensions are as shown in Figure 1-3.
2. Fix the display unit by six pan head screws M4 X 20. Refer to the outline drawing on page D-2.

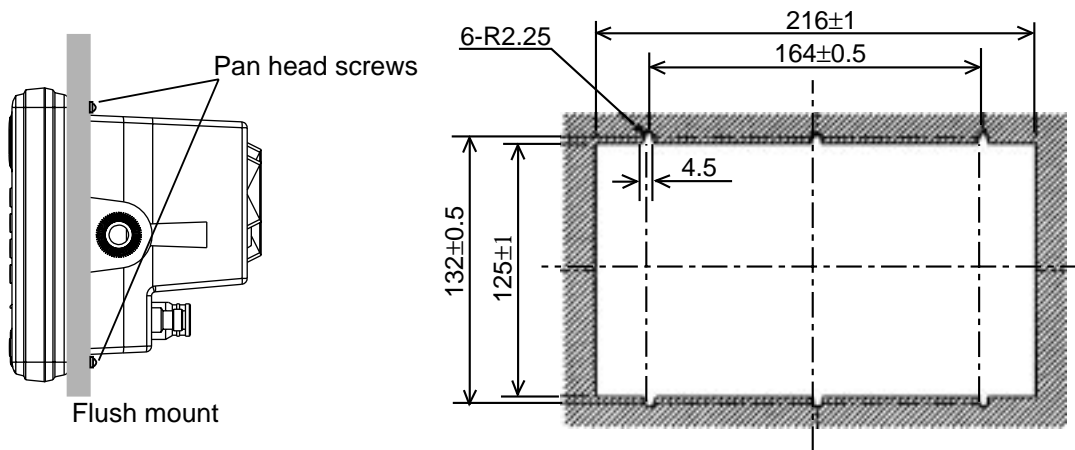


Figure 1-3 Flush mounting of display unit

1.2 Installation of Antenna Unit

Mounting considerations

Install the antenna unit referring to the installation diagram on page D-3 or D-4. When selecting a mounting location for the antenna unit, keep in mind the following points:

- Select a location out of the radar beam. The radar beam will obstruct or prevent reception of the GPS satellite signal.
- The location should be well away from a VHF antenna. A GPS receiver is interfered by a harmonic wave of a VHF antenna.
- There should be no interfering object within the line-of-sight to the satellites. Objects within line-of-sight to a satellite, for example, a mast, may block reception or prolong acquisition time.
- Mount the antenna unit as high as possible. Mounting the antenna unit as high as possible keeps it free of interfering objects and water spray, which can interrupt reception of GPS satellite signal if the water freezes.
- The length of the whip antenna for the GP-1650D should be no longer than 1.2 meter to prevent antenna damage. **Do not use a 2.5 meter whip antenna.**
- Do not shorten the antenna cable.
- If the antenna cable is to be passed through a hole which is not large enough to pass the connector, you may unfasten the connector with a needle nose pliers and 3/8-inch open-end wrench. Re-fasten it as shown in Figure 1-4 after running the cable through the hole.

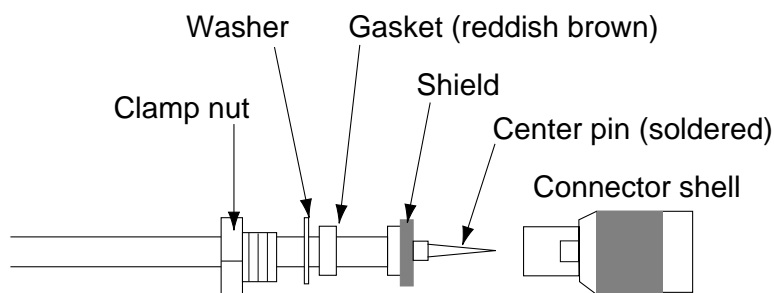


Figure 1-4 How to assemble the connector

2. Wiring

All wiring are terminated at the rear of the display unit.

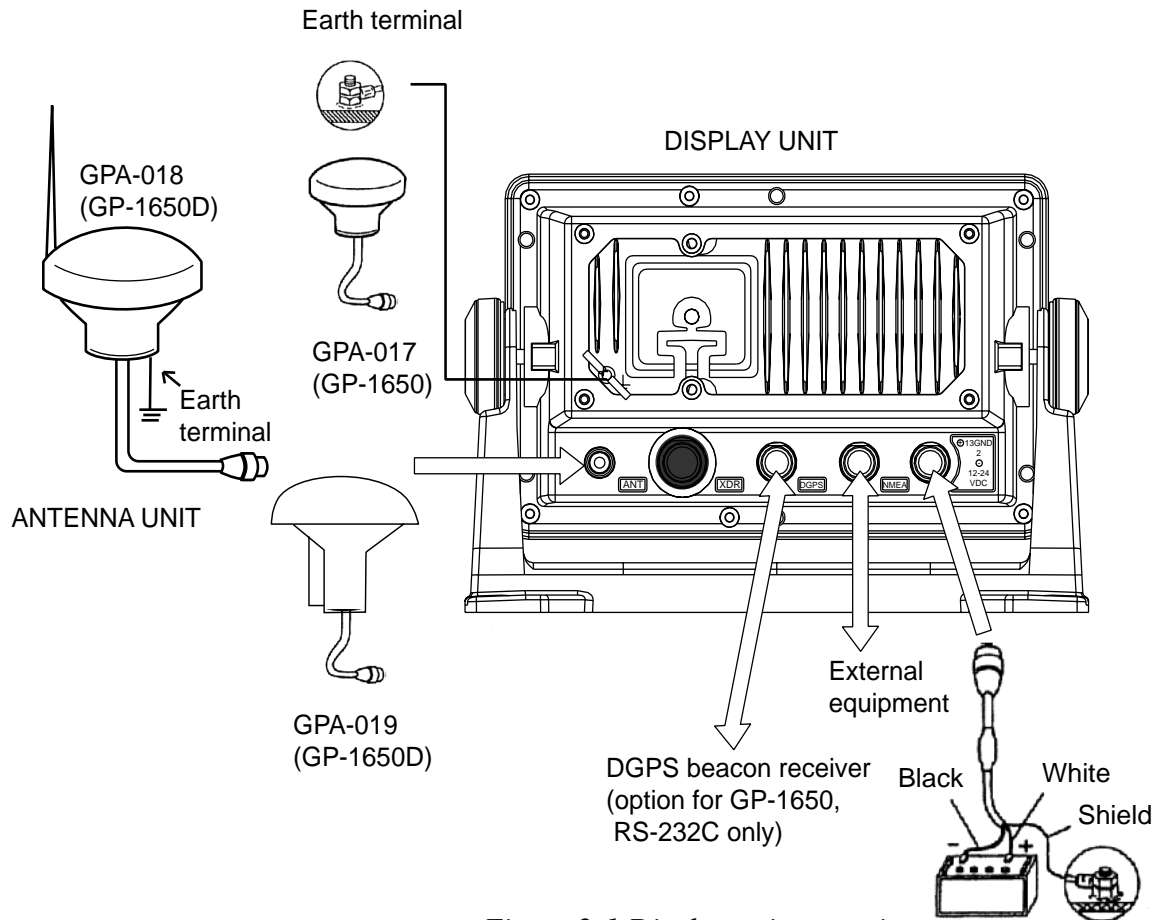


Figure 2-1 Display unit, rear view

Power cable

Connect the power cable to the power connector. Connect the leads to the battery (12 or 24 VDC); white to plus(+) terminal and black to minus(-) terminal.

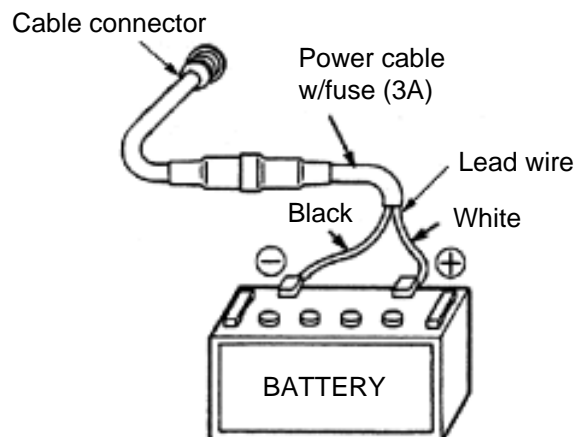


Figure 2-2 Connecting the power cable to the battery

Antenna unit


Connect the antenna unit cable to the ANT connector.

Ground

The display unit contains several CPUs. While they are operating, they radiate noise, which can interfere with radio equipment. Ground the unit to prevent interference. The grounding wire should be 1.25 sq or larger and as short as possible. Connect the grounding wire to ship's ground. On a fiberglass boat, it is best to install a ground plate that measures about 20 cm by 30 cm on the outside of the hull bottom to provide a ground point. If this is not practical, the engine block can be used.



Also, the antenna unit GPA-018S(option) type antenna units should be grounded.

Note: Use a "closed" lug to make the ground connection at the display unit. Do not use an "open-type" lug ().

Extending antenna cable length

The standard cable is 10m long. For extension, in case of the GPA-016, GPA-018or GPA-018S, an antenna cable set of 30m or 50m is available. Extension cable cannot be used with the GPA-017 or GPA-018.

◆ Extension cable line-up

Fabricate the end of the antenna cable and attach the coaxial connector. Details are shown on next page.

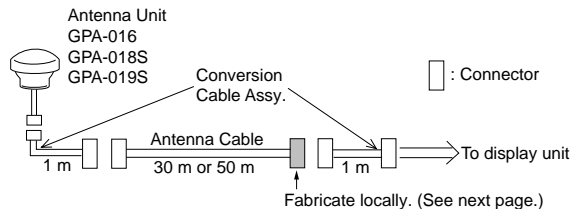


Figure 2-3 Cable extension

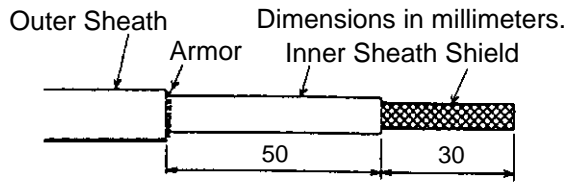
◆ Waterproofing connector

Wrap connector with vulcanizing tape and then vinyl tape. Bind the tape end with cable-tie.

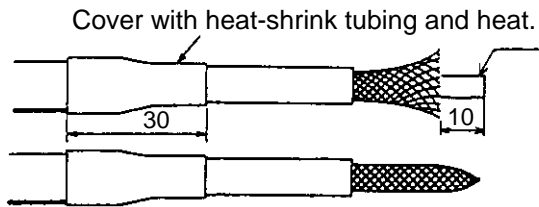


Figure 2-4 Waterproofing connector

How to attach the N-P-8DFB connector

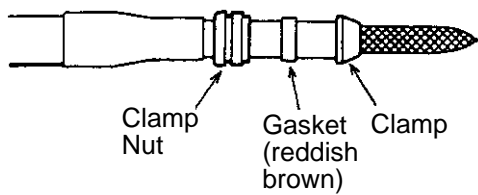


Remove outer sheath and armor by the dimensions shown left.
Expose inner sheath and shield by the dimensions shown left.

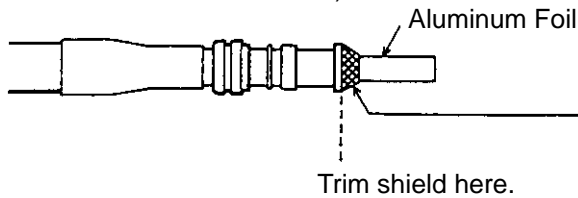


Cut off insulator and core by 10mm.

Twist shield end.



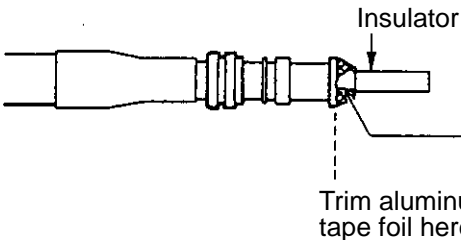
Slip on clamp nut, gasket and clamp as shown left.



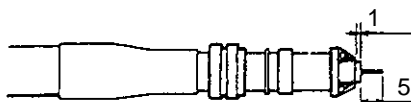
Fold back shield over clamp and trim.



Cut aluminum foil at four places, 90° from one another.

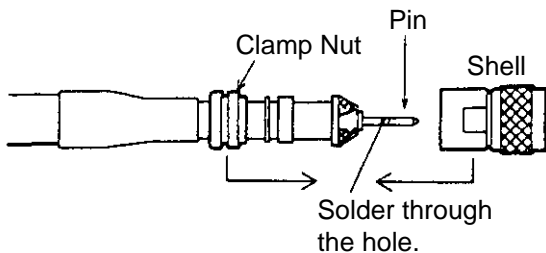


Fold back aluminum foil onto shield and trim.



Expose the insulator by 1mm.

Expose the core by 5mm.



Slip the pin onto the conductor. Solder them together through the hole on the pin.

Insert the pin into the shell. Screw the clamp nut into the shell.
(Tighten by turning the clamp nut. Do not tighten by turning the shell.)

Figure 2-5 Fabrication of coaxial cable

3. Initial Settings

3.1 NMEA Setting

NMEA port

1. Press the [MENU] key.
2. Press the software key labeled "CONFIGURATION".
3. Press the software key labeled "SETUP NMEA PORT1".
4. Select "FORMAT" by the arrow key.
5. Press the software key labeled "EDIT" to display the following message.

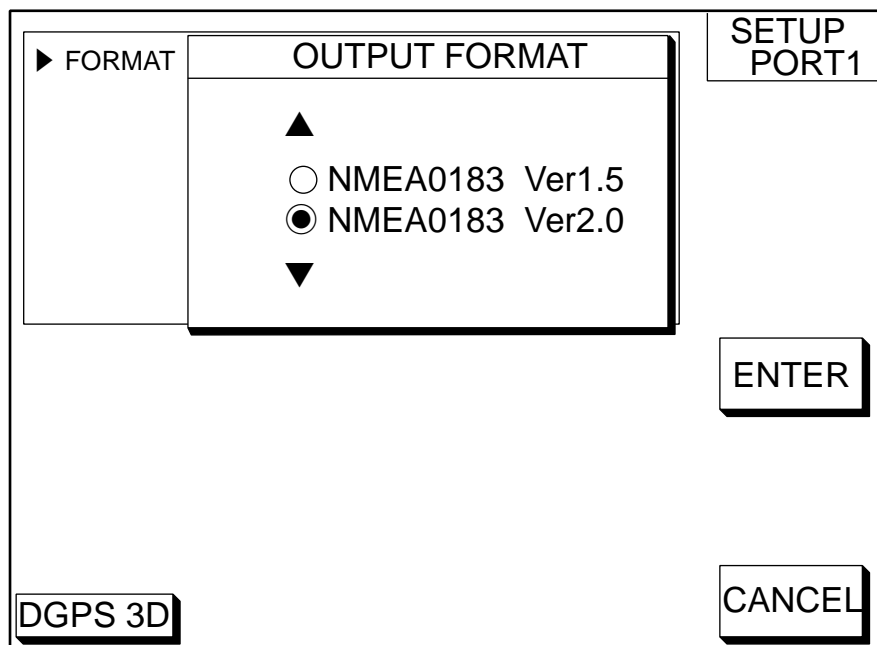


Figure 3-1 Output Format display

6. Select NMEA version by the arrow key. The selected item is indicated by black button.
7. Press the software key labeled "ENTER".
8. Press the [PLOT] key to return to the plotter display.

DGPS port

1. Press the [MENU] key.
2. Press the software key labeled "CONFIGURATION".
3. Press the software key labeled "SETUP NMEA/DGPS PORT2".
4. Select "FORMAT" by the arrow key.
5. Press the software key labeled "EDIT" to display the following message.

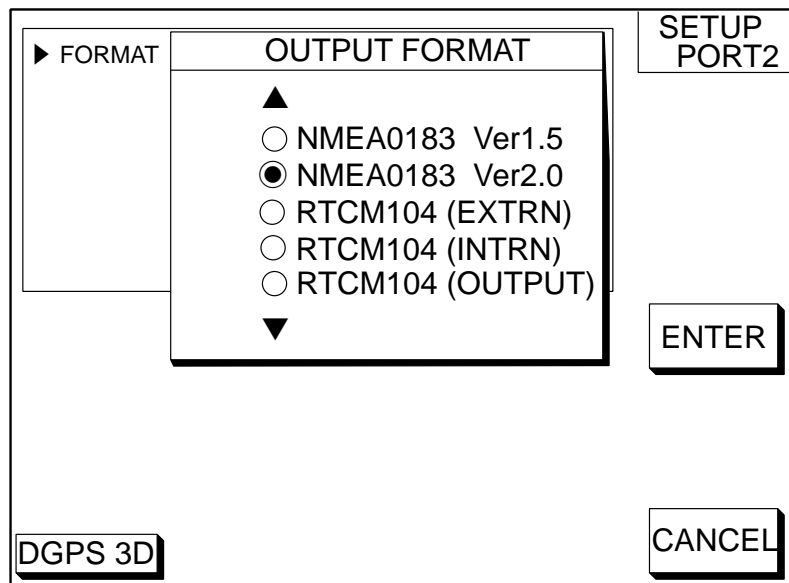


Figure 3-2 Output Format Display

6. Select NMEA version, external DGPS or internal DGPS by the arrow key. The selected item is indicated by black button.

NMEA0183Ver1.5/Ver2.0	:Select one when connecting PC or RS-232C equipment.
RTCM104(EXTRN)	:Select this when connecting external DGPS beacon receiver.
RTCM104(INTRN)	:Select this for builtin internal DGPS beacon receiver.
RTCM104(OUTPUT)	:Select this when outputting deifferential data of the internal DGPS beacon receiver to other GPS navigator.

Note 1) Note that you cannot setup sentences when you select RTCM104 at the format.

Note 2) For RS-422 format, the level converter (IF-1432) is required for connection of external equipmemt.

7. Press the software key labeled "ENTER".
8. Press the [PLOT] key to return to finish.

3.2 Output Data Sentences

Select output data sentences for external equipment as follows:.

1. Press the [MENU] key.
2. Press the software key labeled "CONFIGURATION".
3. Press the software key labeled "SETUP NMEA PORT1".
4. Press the software key labeled "SELECT SNTNC." to display the following list.

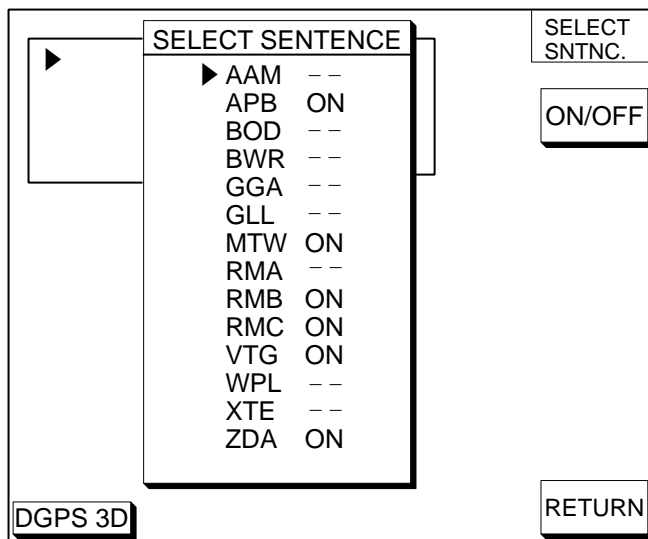


Figure 3-3 Output Data Sentences Display

5. Select data sentence you want to output by the arrow key.
6. Press the software key labeled "ON/OFF". To output data, set to "ON".
7. Repeat to select other sentences.
8. Press the software key labeled "RETURN".
9. Press the [PLOT] key to return the plotter display.

Input/Output data sentences

Port		Format	Data	Remarks
NMEA	Input	• NMEA-0183 Ver. 2.0	TLL*1, DWM, WPL*1, DBT/DPT	WPL : GP only NMEA Ver 1.5: DBT NMEA Ver 2.0: DPT
	Output	• IEC1162	AAM, APB, BOD, BWC/BWR, GGA, GLL, RMA, RMB, RMC, VTG, WPL, XTE, ZDA, MTW, GTD*2	GREAT CIRCLE: BWC RHUMB LINE: BWR
DGPS	Input	• NMEA-0183 Ver. 2.0	TLL*1, MTW, WPL*1, DBT/DPT	WPL: GP only NMEA Ver 1.5: DBT NMEA Ver 2.0: DPT
	Output	• RS232C • RTCM104	AAM, APB, BOD, BWC/BWR, GGA, GLL, RMA, RMB, RMC, VTG, WPL, XTE, ZDA, MTW, GTD*2	GREAT CIRCLE: BWC RHUMB LINE: BWR

*1: Cannot be input consecutively.

*2: Output automatically when LC or LA is selected.

3.3 Antenna Height

1. Press the [MENU] key.
2. Press the software key labeled "GPS/DGPS/TD OPTIONS".
3. Press the software key labeled "GPS SETUP OPTIONS".
4. Select "ANT. HEIGHT" by the arrow key.
5. Press the software key labeled "EDIT".

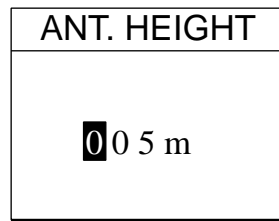


Figure 3-4 Antenna Height Display

6. Enter the height (3 digits) of the antenna above sea level using the numeric keys.
If you enter wrong antenna height, press the software key labeled "CLEAR".
7. Press the [ENTER] key.
8. Press the [PLOT] key to return the plotter display.

3.4 Baud Rate Setting (GP-1650D only)

1. Press the [MENU] key.
2. Press the software key labeled "GPS/DGPS/TD OPTIONS".
3. Press the software key labeled "DGPS SETUP OPTIONS" to display the following message.

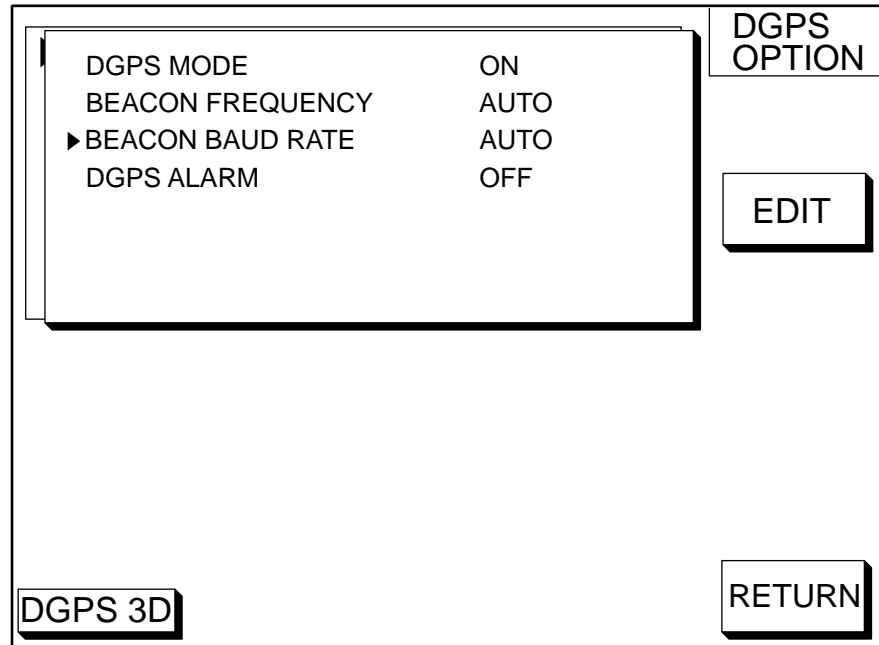


Figure 3-5 DGPS Setup Options Display

4. Confirm that "ON" is selected at "DGPS MODE" field for GP-1650D.
5. Select "BEACON BAUD RATE" by the arrow key.
6. Press the software key labeled "EDIT" to display the following message. Beacon baud rate cannot be set when "BEACON FREQUENCY" is set to "AUTO".

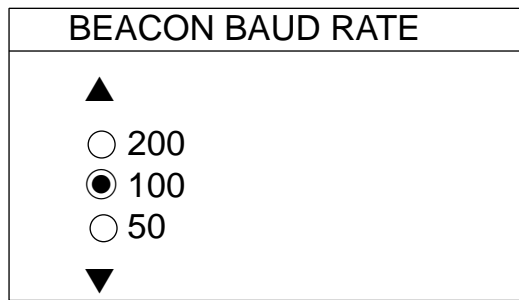


Figure 3-6 Beacon Baud Rate Display

7. Select beacon baud rate corresponding to DGPS reference station to use.
8. Press the [ENTER] key.
9. Press the [PLOT] key to return the plotter display.

3.5 Beacon frequency Setting (GP-1650D only)

1. Press the [MENU] key.
2. Press the software key labeled "GPS/DGPS/TD OPTIONS".
3. Press the software key labeled "DGPS SETUP OPTIONS" to display the following message.

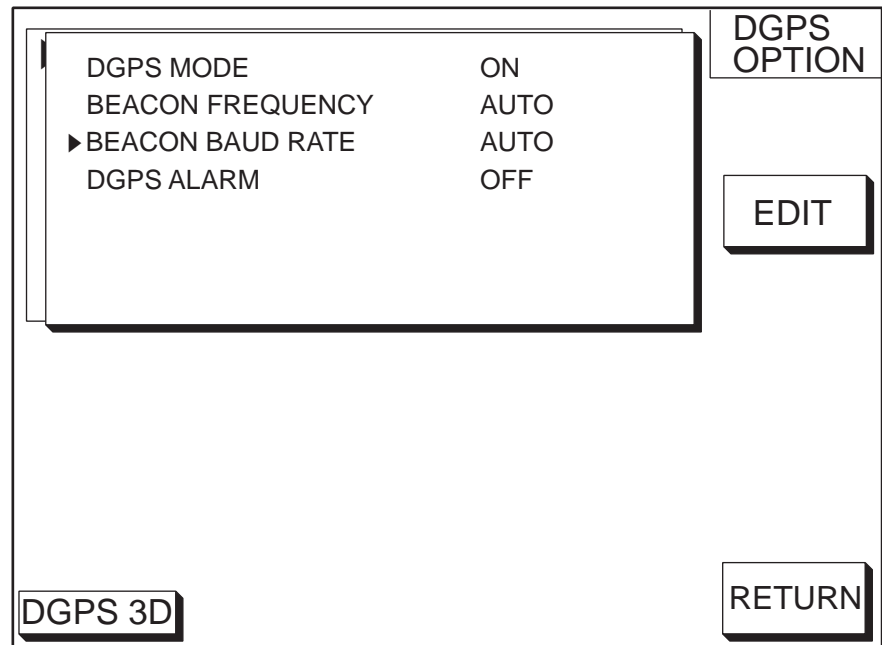


Figure 3-7 DGPS Setup Options Display

4. Select "BEACON FREQUENCY" by the arrow key.
5. Press the software key labeled "EDIT" to display the following message.

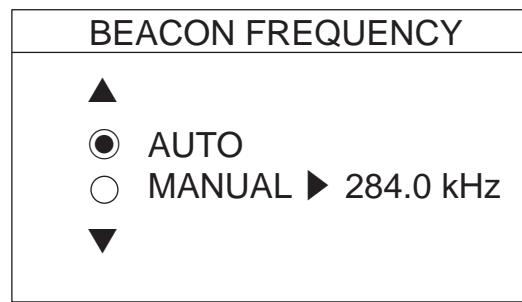


Figure 3-8 Beacon Frequency Display

6. Select "AUTO" or "MANUAL" by the arrow key. When you select "MANUAL", operate the cursor pad to move the cursor to frequency dialog box. And press the arrow key to select the frequency desired.
7. Press the [ENTER] key.
8. Press the [PLOT] key to return to finish.

4. Installation of DGPS Beacon Receiver (for GP-1650)

The DGPS beacon receiver GR-7000A can be incorporated in the GP-1650 to provide it with DGPS capability. Six installation kits are available as shown.

GR-802-1650-10A-018 GR-802-1650-10N-018 (No whip ant.)

Name	Type	Code No.	Qty
Antenna Unit	GPA-018S	000-041-462	1
Beacon Receiver	GR-7000A	000-143-249	1
Cable Assy.	TNC-PS-3D-15	000-133-670	1
Connector Assy.	PH6P-W-L240	000-141-548	1
Pan head screws	M3X10 C2700W	000-881-405	4
Cable tie	CV-100	000-570-322	2
Screw*	M3X12 SUS304	000-805-905	6
Cable Assy.	S.FL2-2LP0.7-D-WHT (121)	000-141-491	1
Whip antenna (15A type only)	FAW-1.2	000-130-046	1
Clamp	HP-2N	000-570-000	1
Cable Assy.*	S.FL2-2LP0.7-D-WHT (250)	000-143-877	1
Screw*	3X8 SUS410	000-802-951	4

* Not used

GR-802-1650-15A-018S GR-802-1650-15N-018S (No whip ant.)

Name	Type	Code No.	Qty
Antenna Unit	GPA-018S	000-041-462	1
Beacon Receiver	GR-7000A	000-143-249	1
Cable Assy.	TNC-PS-3D-15	000-133-670	1
Connector Assy.	PH6P-W-L240	000-141-548	1
Pan head screws	M3X10 C2700W	000-881-405	4
Cable tie	CV-100	000-570-322	2
Screw*	M3X12 SUS304	000-805-905	6
Cable Assy.	S.FL2-2LP0.7-D-WHT (121)	000-141-491	1
Whip antenna (15A type only)	FAW-1.2	000-130-046	1
Clamp	HP-2N	000-570-000	1
Cable Assy.*	S.FL2-2LP0.7-D-WHT (250)	000-143-877	1
Screw*	3X8 SUS410	000-802-951	4

* Not used

GR-802-1650-10N-019 (No whip ant.)

Name	Type	Code No.	Qty
Antenna Unit	GPA-019	000-041-552	1
Beacon Receiver	GR-7000A	000-143-249	1
Connector Assy.	PH6P-W-L240	000-141-548	1
Pan head screws	M3X10 C2700W	000-881-405	4
Cable tie	CV-100	000-570-322	2
Screw*	M3X12 SUS304	000-805-905	6
Cable Assy.	S.FL2-2LP0.7-D-WHT (121)	000-141-491	1
Clamp	HP-2N	000-570-000	1
Cable Assy.*	S.FL2-2LP0.7-D-WHT (250)	000-143-877	1
Screw*	3X8 SUS410	000-802-951	4

* Not used

GR-802-1650-15N-019S (No whip ant.)

Name	Type	Code No.	Qty
Antenna Unit	GPA-019S	000-041-554	1
Beacon Receiver	GR-7000A	000-143-249	1
Cable Assy.	TNC-PS-3D-15	000-133-670	1
Connector Assy.	PH6P-W-L240	000-141-548	1
Pan head screws	M3X10 C2700W	000-881-405	4
Cable tie	CV-100	000-570-322	2
Screw*	M3X12 SUS304	000-805-905	6
Cable Assy.	S.FL2-2LP0.7-D-WHT (121)	000-141-491	1
Clamp	HP-2N	000-570-000	1
Cable Assy.*	S.FL2-2LP0.7-D-WHT (250)	000-143-877	1
Screw*	3X8 SUS410	000-802-951	4

* Not used

Disassembly

Procedure

1. Turn off the power. Wait at least one minute before opening the cover, to allow capacitors to discharge.
2. Remove nuts attached to DGPS, NMEA and power supply connectors at the rear of the display unit.

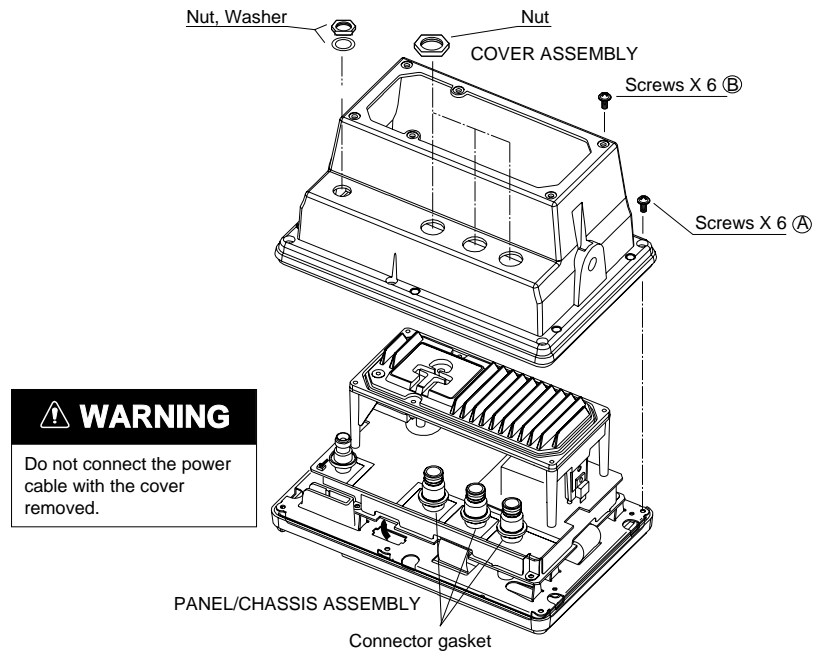


Figure 4-1 Removing cover assembly

3. Remove nuts and washer attached to ANT connector.
4. Remove twelve screws at rear of the display unit to detach panel/chassis assembly from cover assembly. Discard six screws (A) (3X12).

Installation of DGPS receiver

Procedure

1. Disconnect 8P connector as shown in the figure below.

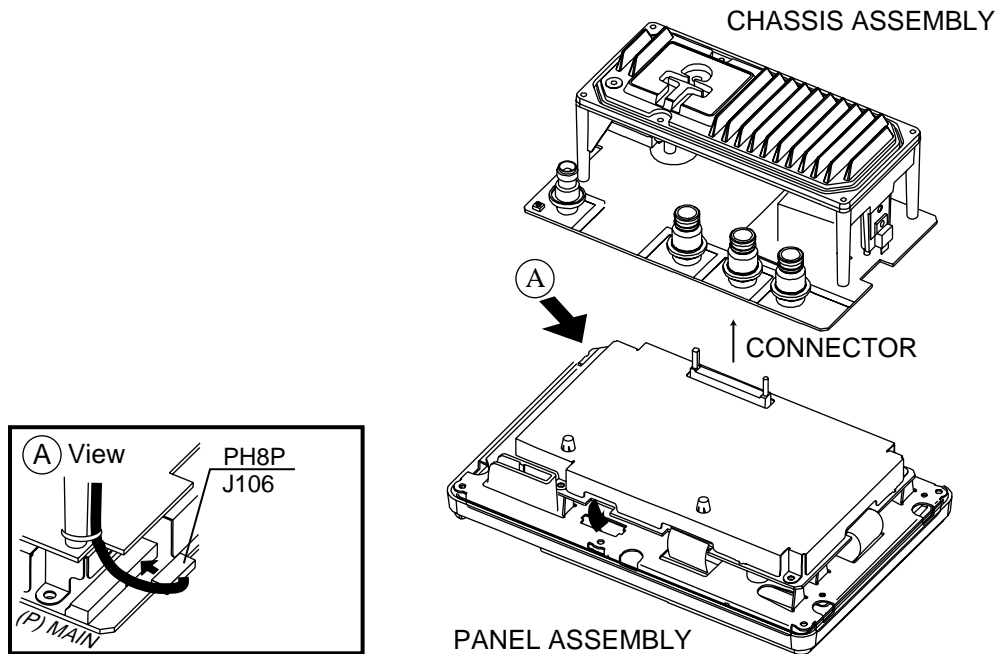


Figure 4-2 Dismounting chassis assembly

2. Dismount chassis assembly from panel assembly by disconnecting connector shown in the figure above.
3. Cut the cable ties as shown in the figure below.

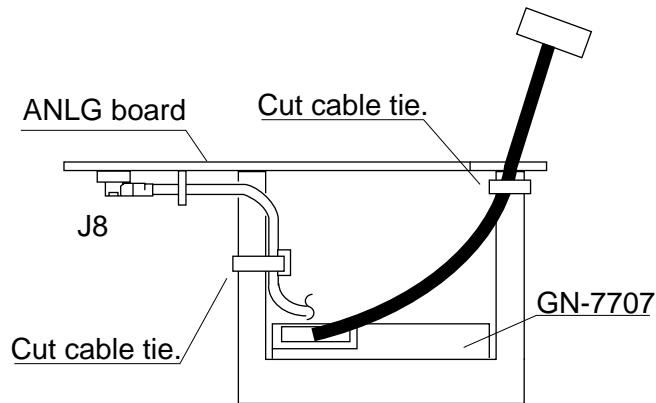


Figure 4-3 Cutting cable ties

4. Dismount heat sink from chassis assembly by unfastening four screws on the ANLG board and disconnecting the connector of the mini pin coaxial cable.

Handling of Coaxial Cable

- Do not touch the connector with bare hands; use gloves.
- Use radio pincers to remove, and pull out straightly.
- Plug in connector straightly.

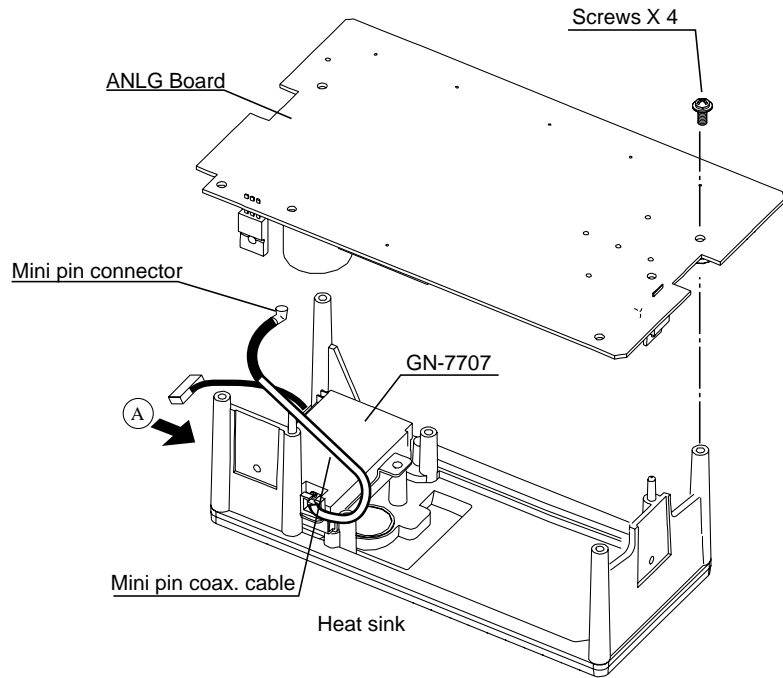


Figure 4-4 Chassis assembly

5. Take off the mini pin coaxial cable from J2 on the GN-7707.
6. Open the lid of GR-7000A.
7. Connect the mini pin coaxial cable to J1 of GR-7000A.

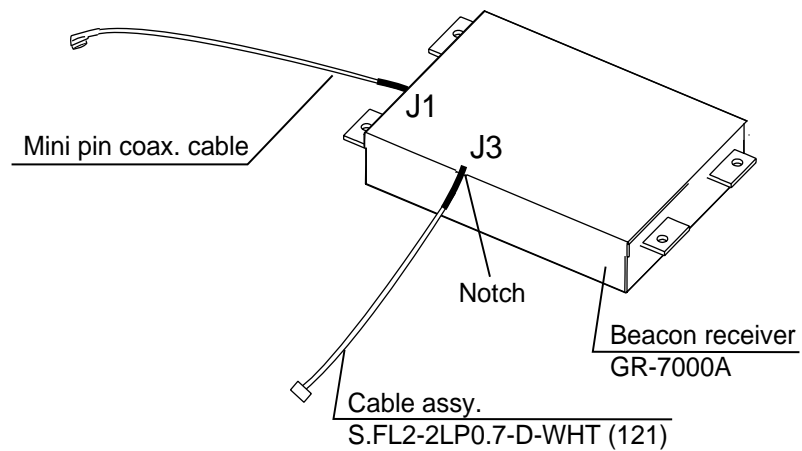


Figure 4-5 Beacon receiver

8. Connect cable assy. S.FL2-2LP0.7-D-WHT (121) (supplied) to J3 of the GR-7000A.
9. Close the lid of the GR-7000A.
10. Connect connector assy. PH6P-W-L240 to J2 of GR-7000A (Refer to Figure 4-6).
11. Fasten the GR-7000A (Beacon receiver) to the heat sink with four M3X10 screws (supplied) as shown in the figure below.

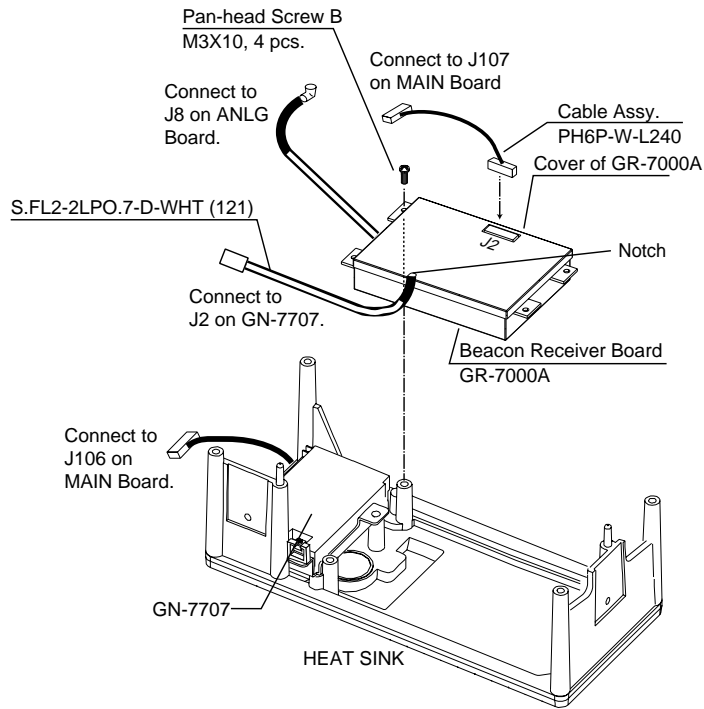


Figure 4-6 Installation of DGPS beacon receiver

12. Connect the cable assy. S.FL2-2LPO.7-D-WHT (121) of J3 to J2 of the GN-7707.
13. Pass the mini pin coaxial cable of J1 on the GR-7000A through the mini plug on the ANLG Board and connect it to J8 on the ANLG Board.
14. Mount the ANLG board on the heat sink.

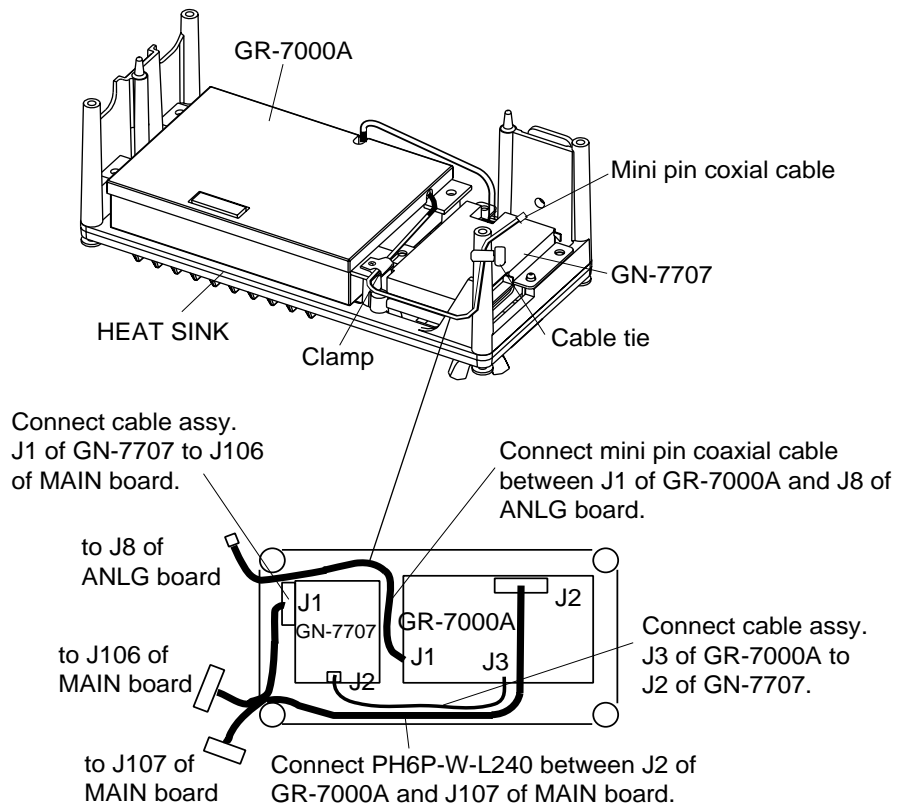


Figure 4-7 Wiring the Cable assembly

15. Mount chassis assembly on the panel assembly. Connect 8P connector and 6P connector to Main board as shown in the figure below.

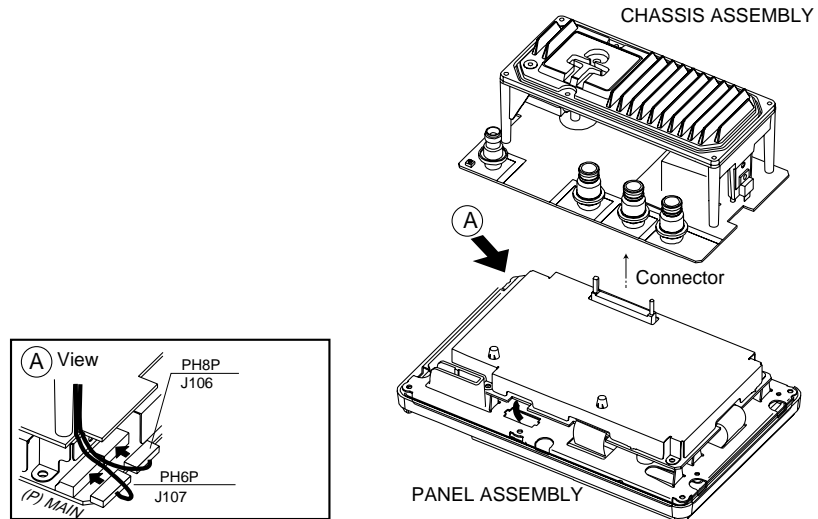


Figure 4-8 Attaching chassis assembly

16. Fasten 8P connector cable and 6P connector cable by cable tie as shown in the figure below. Fasten mini pin coaxial cable by cable tie as shown in the figure.

Note: After connecting, pull up cable to remove slack so as not to pinch the cable between cover panel assembly.

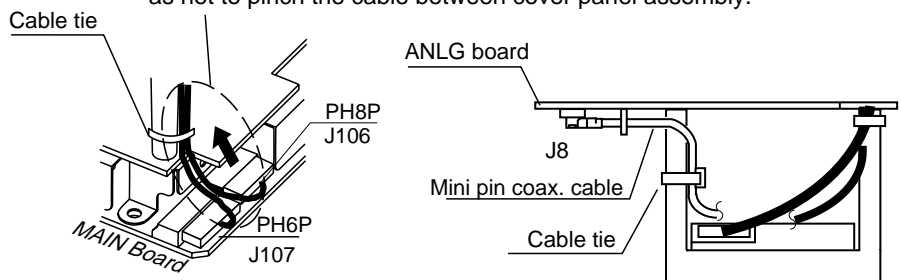


Figure 4-9 Attaching cable tie

17. Reassemble the display unit.
Use new screws size 3X12 (supplied).

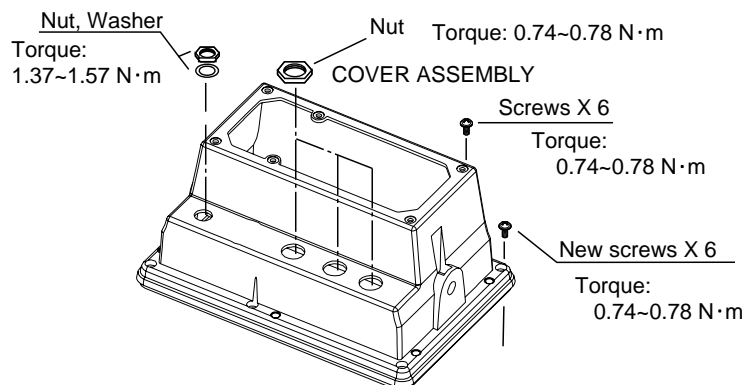


Figure 4-10 Remounting the cover

Note: When reattaching the cover, confirm the following parts are attached.

Shield gasket, cover gasket (See figure 4-11.)

Connector gasket (See figure 4-1.)

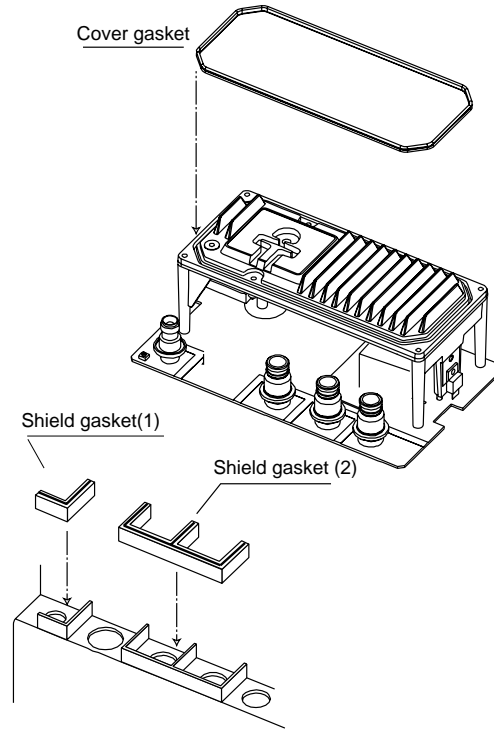
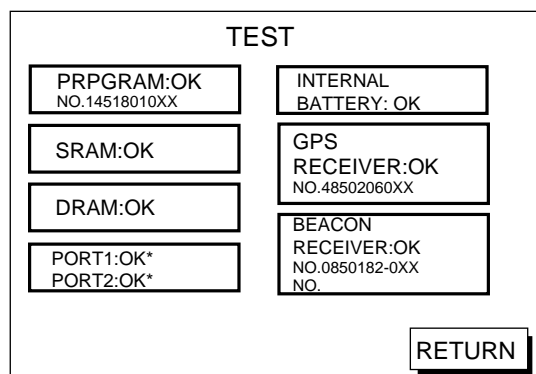


Figure 4-11 Gaskets

Checking the DGPS installation

1. Press the [MENU] key.
2. Press the software key labeled "CONFIGURATION".
3. Press the software key labeled "SYSTEM MENU".
4. Press the software key labeled "SELF TEST".
5. Press the software key labeled "MEMORY•I/O TEST" to display the following message.



*Special connections are required to check these ports. Otherwise, NG appears.

Figure 4-12 Memory, I/O Test Display

6. Confirm that "BEACON RECEIVER: OK" is displayed.
7. Press the software key labeled "RETURN".
8. Press the [PLOT] key to return the plotter display.

Connecting DGPS beacon receiver

A DGPS beacon receiver whose output format is RS-232C can be connected to the GP-1650.

Below is the example of interconnection between the GP-1650 and FURUNO beacon receiver GR-80.

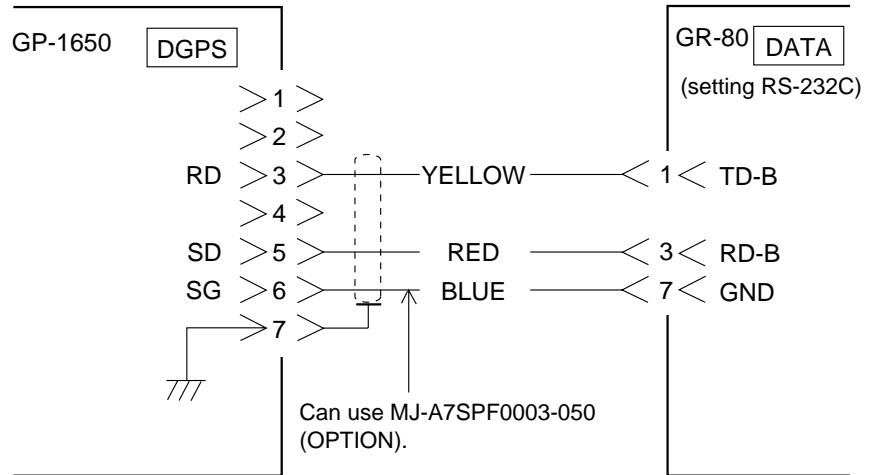
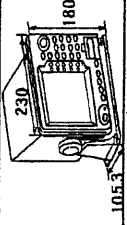
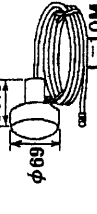


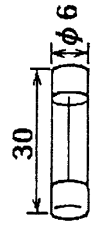
Figure 4-13 Connecting DGPS beacon receiver

PACKING LIST GP-1650/1650F (E017)

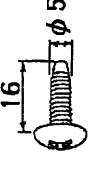
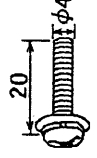
14CE-X-9854-2 1/1

NAME	OUTLINE	DESCRIPTION/CODE No.	Q'TY
ユニット			
指示器		GP-1650-E	1
DISPLAY UNIT		000-041-476**	
空中線部		GPA-017	1
ANTENNA UNIT		000-041-403	

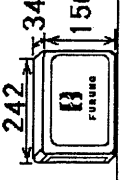
予備品 SPARE PARTS SP14-02401

ヒューズ		FG80-A 3A AC125V	3
FUSE		000-549-063	



付属品 ACCESSORIES FP14-02302

+トラスピピンネジ		5X16 SUS304 1種	4
+TAPPING SCREW		000-805-494	
+ナベトラスピB		MAX20 SUS304	6
WASHER HEAD SCREW		000-804-742	

付属品 ACCESSORIES FP14-02301

ハードカバー組品		FP14-02301	1
HARD COVER ASSY.		004-375-830	

その他工材 OTHER INSTALLATION MATERIALS

NAME	OUTLINE	DESCRIPTION/CODE No.	Q'TY
ケーブル組品MJ		MJ-A3SPF0013-035	1
POWER CABLE		000-135-397	
ケーブル組品MJ		MJ-A6SPF0003-050	1
CABLE ASSY.		000-117-603	

注記) コード末尾に[*]の付いたユニットは代表の型式/コードを表示しています。
 DOUBLE ASTERISK DENOTES COMMONLY USED EQUIPMENT.
 2.送受信機他オプション等は別梱包になります。
 OPTIONS, FOR EXAMPLE TRANSDUCER ARE SUPPLIED IN OTHER BOX.

(略図の寸法は、参考値です。 DIMENSIONS IN DRAWING FOR REFERENCE ONLY.)

DWG NO. C4394-Z06-A A-1

PACKING LIST GP-1650D/1650DF (E018)

14CE-X-9852-5 1/1

NAME	OUTLINE	DESCRIPTION/CODE No.	Q'TY
ユニット UNIT			
空中線部		GPA-018	1
ANTENNA UNIT		000-041-407	
指示器		GP-1650D-E	1
DISPLAY UNIT		000-041-477**	

予備品 SPARE PARTS SP14-02401

ヒューズ		FGBO-A 3A AC125V	3
FUSE		000-549-063	

付属品 ACCESSORIES FP14-02302

+ナット M4X20 B		M4X20 SUS304	6
WASHER HEAD SCREW		000-804-742	
+トラスタップネジ		5X16 SUS304 1種	4
+TAPPING SCREW		000-805-494	

付属品 ACCESSORIES FP14-02301

ハードカバー組品		FP14-02301	1
HARD COVER ASSY.		004-375-830	

その他工材 OTHER INSTALLATION MATERIALS

NAME	OUTLINE	DESCRIPTION/CODE No.	Q'TY
ケーブル組品MJ		MJ-A3SPF0013-035	1
POWER CABLE		000-135-397	
ケーブル組品MJ		MJ-A6SPF0003-050	1
CABLE ASSY.		000-117-603	

注記) コード末尾に[*]の付いたユニットは代表の型式/コードを表示しています。
 DOUBLE ASTERISK DENOTES COMMONLY USED EQUIPMENT.
 2.ホイップアンテナ、送受信機他オプション等は別梱包になります。
 OPTIONS, FOR EXAMPLE WHIP ANTENNA, TRANSDUCER ARE SUPPLIED IN OTHER BOX.

(略図の寸法は、参考値です。 DIMENSIONS IN DRAWING FOR REFERENCE ONLY.)

DWG NO. C4394-Z02-C

A-2

PACKING LIST GP-1650D/1650DF (E019)

14CE-X-9856-3 1/1

NAME	OUTLINE	DESCRIPTION/CODE No.	Q'TY
ユニット UNIT			
指示器		GP-1650D-E	1
DISPLAY UNIT		000-041-477**	
空中線部		GPA-019	1
ANTENNA UNIT		000-142-416	

予備品 SPARE PARTS SP14-02401

ヒューズ		FG80-A 3A AC125V	3
FUSE		000-549-063	

付属品 ACCESSORIES FP14-02302

+トラスヘッドネジ		5X16 SUS304 1種	4
+TAPPING SCREW		000-805-494	
+ワッシャーネジ B		M4X20 SUS304	6
WASHER HEAD SCREW		000-804-742	

付属品 ACCESSORIES FP14-02301

ハードカバー組品		FP14-02301	1
HARD COVER ASSY.		004-375-830	

その他工材 OTHER INSTALLATION MATERIALS

NAME	OUTLINE	DESCRIPTION/CODE No.	Q'TY
ケーブル組品MJ		MJ-A3SPF0013-035	1
POWER CABLE		000-135-397	
ケーブル組品MJ		MJ-A6SPF0003-060	1
CABLE ASSY.		000-117-603	

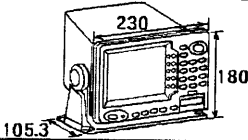
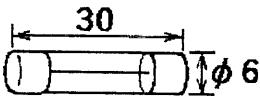
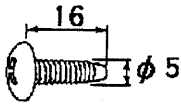
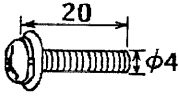
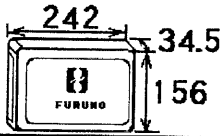


注記) コード末尾に[**]の付いたユニットは代表の型式/コードを表示しています。
 DOUBLE ASTERISK DENOTES COMMONLY USED EQUIPMENT.
 2.送受信機他オプション等は別梱包になります。
 OPTIONS, FOR EXAMPLE TRANSDUCER ARE SUPPLIED IN OTHER BOX.

(略図の寸法は、参考値です。 DIMENSIONS IN DRAWING FOR REFERENCE ONLY.)

DWG NO. C4394-Z04-B

PACKING LIST

GP-1650D/1650DF (E/J)

NAME	OUTLINE	DESCRIPTION/CODE No.	Q'TY
ユニット UNIT			
指示器 DISPLAY UNIT		GP-1650D-J 000-041-541 **	1
予備品 SPARE PARTS		SP14-02401	
ヒューズ FUSE		FGBO-A 3A AC125V 000-549-063	3
付属品 ACCESSORIES		FP14-02302	
+トラスタップ・ソネジ +TAPPING SCREW		5X16 SUS304 1種 000-805-494	4
+ナベ・セムソネジ B WASHER HEAD SCREW		M4X20 SUS304 000-804-742	6
付属品 ACCESSORIES		FP14-02301	
ハードカバー組品 HARD COVER ASSY.		FP14-02301 004-375-830	1
その他工材 OTHER INSTALLATION MATERIALS			
ケーブル組品MJ POWER CABLE		MJ-A3SPF0013-035 000-135-397	1
ケーブル組品MJ CABLE ASSY.		MJ-A6SPF0003-050 000-117-603	1

注記) コード末尾に[**]の付いたユニットは代表の型式/コードを表示しています。

DOUBLE ASTERISK DENOTES COMMONLY USED EQUIPMENT.

2.送受波器他オプション等は別梱包になります。

OPTIONS, FOR EXAMPLE TRANSDUCER ARE SUPPLIED IN OTHER BOX.

(略図の寸法は、参考値です。 DIMENSIONS IN DRAWING FOR REFERENCE ONLY.)

DWG NO.

C4394-207-B

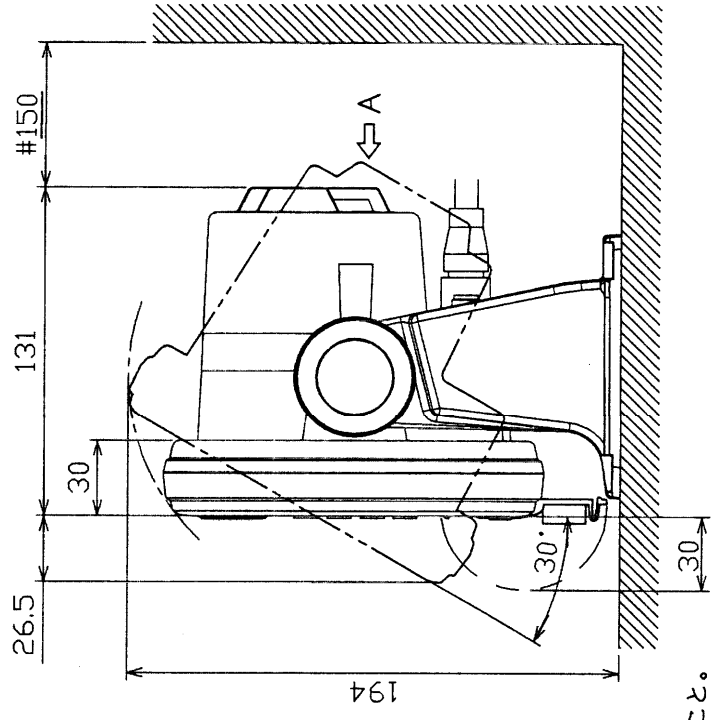
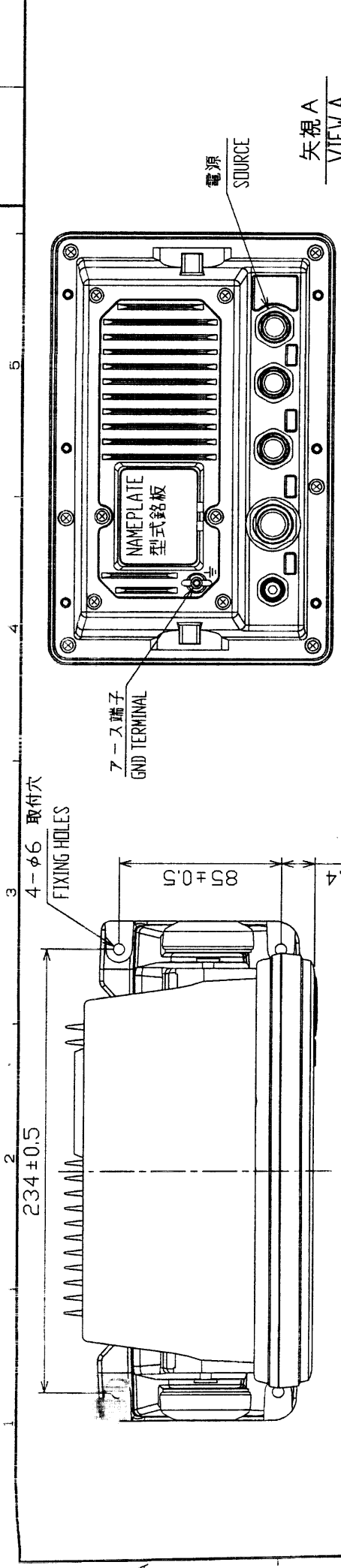


表 1 TABLE 1

寸法区分 (mm) DIMENSION	公差 (mm) TOLERANCE
L ≤ 50	±1.5
50 < L ≤ 100	±2.5
100 < L ≤ 500	±3

表 2 TABLE 2

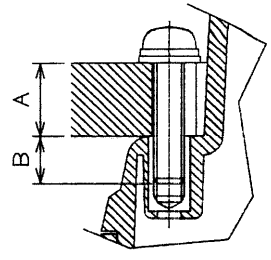
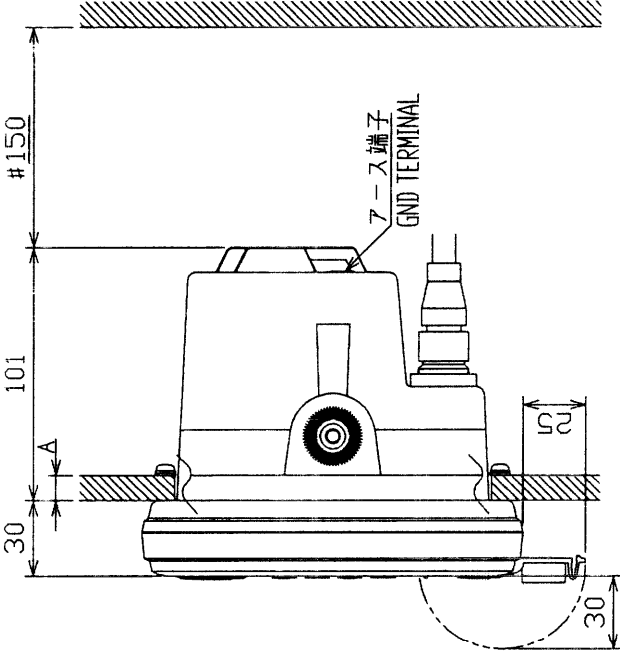
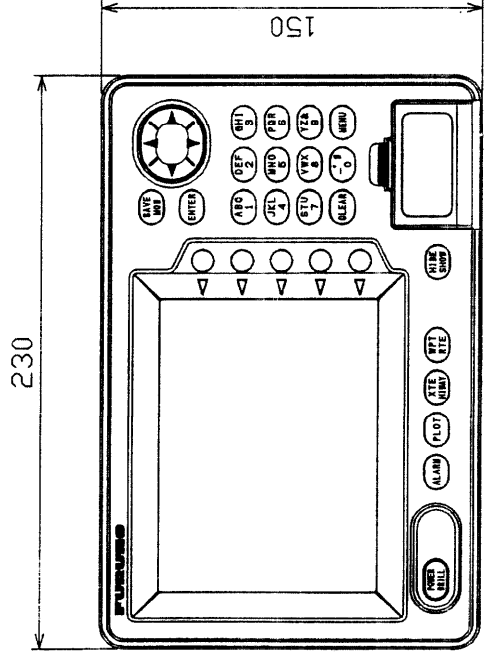
機種名 TYPE	質量 (kg) MASS
GP-1650	2.0
GP-1650D	2.2

DRAWN Feb. 5 '02 T. YAMASAKI	TITLE GP-1650/1650D
CHECKED Feb. 5 '02 Y. K.	名称 指示部 (卓上装備)
APPROVED Feb. 5 '02 Y. K.	外寸図
SCALE 1/3	WAVE DISPLAY UNIT (DESKTOP MOUNT)
DRAWING No. C4394-001-D	OUTLINE DRAWING 14-062-1000G-1

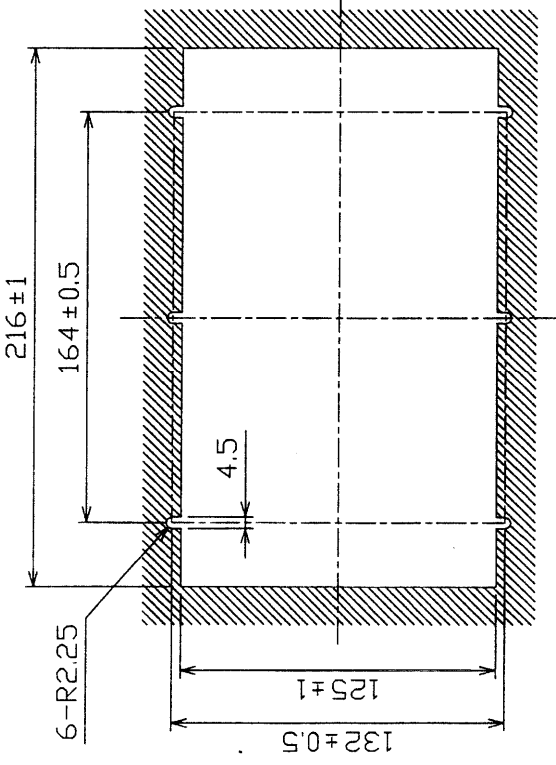
注 記 1) 装備ケーブルはサービス時、本体を前方に十分引き出せるよう余裕を持たせること。
 2) 取付用ネジはトラスクッピンネジ呼び径5×2.0を使用のこと。
 3) 指定外寸法公差は、表1による。
 4) #印寸法は最小サービス空間とする。

NOTE 1. KEEP SUFFICIENT CABLE LENGTH BEHIND UNIT.
 2. USE TAPPING SCREWS 5x16 FOR FIXING THE UNIT.
 3. TABLE 1 INDICATES TOLERANCE OF DIMENSIONS.
 4. # RECOMMENDED SERVICE CLEARANCE.

2 3 4 5



取付ネジ部断面
(尺度 1/1)
DETAIL FOR FASTENING
(SCALE 1/1)



取付穴寸法図
CUTOUT DIMENSIONS

- 注記 1) 装備ケーブルはサービスタブを前方に十分引き出せるよう余裕を持たせること。
 2) 指定外寸法公差は表 1 による。
 3) #印寸法は最小サービスタブ間とする。
 4) 取付にはセムスネジ B M4×2.0 を使用のこと。
 壁の厚さ(A)は $11 \leq A \leq 14$ とする。それ以外の壁に装備する場合、使用するネジ長さは $(A+7.8) \pm 1.5$ とする。筐体にはネジ部(B)を 8 mm 以上いれないこと。

NOTE

- KEEP SUFFICIENT CABLE LENGTH BEHIND UNIT.
- TABLE 1 INDICATES TOLERANCE OF DIMENSIONS.
- # RECOMMENDED SERVICE CLEARANCE.
- USE M4x2.0 SEMS SCREWS FOR FIXING THE UNIT.
 THICKNESS (A): $11 \leq A \leq 14$, OTHERWISE SCREW LENGTH: $(A+7.8) \pm 1.5$
 DO NOT FASTEN SCREWS INTO UNIT MORE THAN 8 mm. (B \leq 8)

機種名 TYPE	質量 (kg) MASS
GP-1650	1.7
GP-1650D	1.9

表 2 TABLE 2

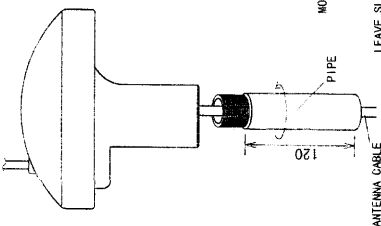
寸法区分 (mm) DIMENSION	公差 (mm) TOLERANCE
$L \leq 50$	± 1.5
$50 < L \leq 100$	± 2.5
$100 < L \leq 500$	± 3

表 1 TABLE 1

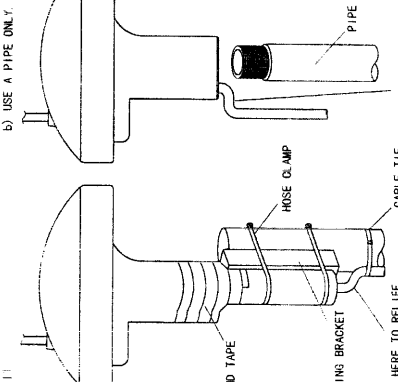
DRAWN Feb. 5 '02 T. YAMASAKI	TITLE GP-1650/1650D
CHECKED Feb. 5 '02 Y. K.	名称 指示部 (埋込装備)
APPROVED Feb. 5 '02 Y. K.	外寸図
SCALE 1/3 MASS #2 (TABLE 2)	NAME DISPLAY UNIT (FLASH MOUNT)
DWG No. C4394-G02-D	PLT LINE DRAWING 14-062-110G-1

A) MAST MOUNTING

a) USE MAST MOUNTING KIT GP20-01111



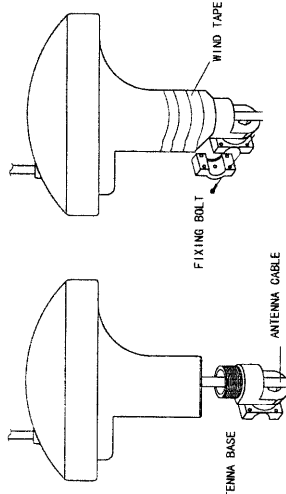
LEAVE SLACK HERE TO RELIEF STRESS ON CONNECTOR



LEAVE SLACK HERE TO RELIEF STRESS ON CONNECTOR

B) HANDRAIL MOUNTING

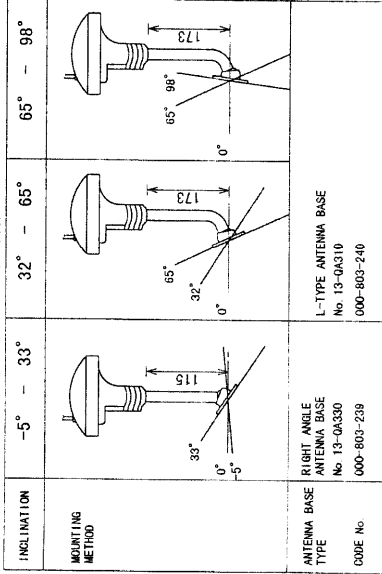
USE HANDRAIL MOUNTING BASE No. 13-RC5180 (CODE No. 000-806-114, OPT10N). THE DIAMETER OF THE HANDRAIL MAY BE FROM $\phi 19\text{mm}$ TO $\phi 32\text{mm}$.



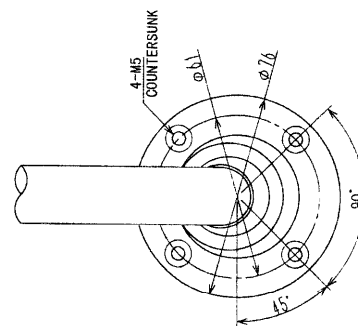
NOTE 1. FASTEN PIPE (ANTENNA BASE) TO ANTENNA UNIT FIRST THEN FIX THEM TO MAST OR HANDRAIL.
2. WHEN FIXING ANTENNA, TURN PIPE OR ANTENNA BASE; NOT THE ANTENNA. TURNING THE ANTENNA MAY TWIST THE CABLE AND PLACE STRESS ON CONNECTOR.

C) ANTENNA BASE MOUNTING

USE OPTIONAL ANTENNA BASE No. 13-QA330/QA310.

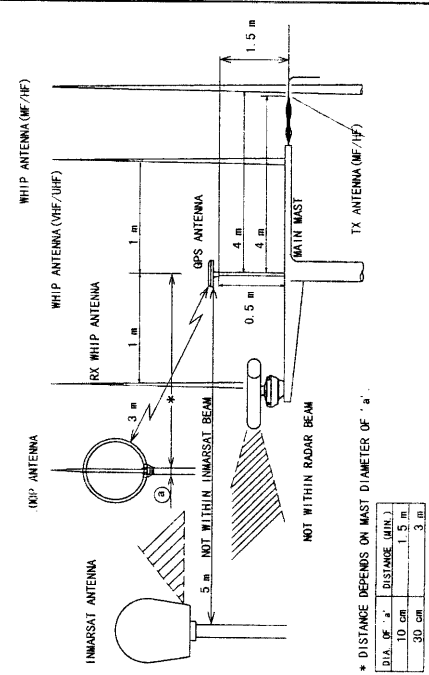


MOUNTING DIMENSIONS OF ANTENNA BASE



MOUNTING LOCATION

THE FIGURE BELOW SHOWS THE RECOMMENDED SEPARATION DISTANCES FROM OTHER ANTENNAS TO AVOID MUTUAL INTERFERENCE



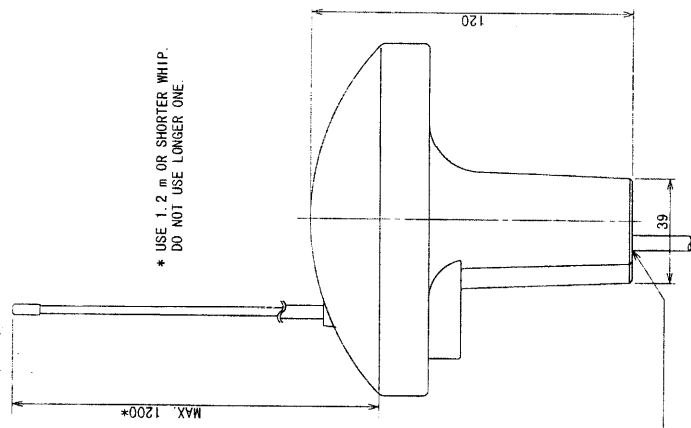
* DISTANCE DEPENDS ON MAST DIAMETER OF "a".

DIA. OF "a" DISTANCE (MIN.)	1.5 m	3 m
30 cm		

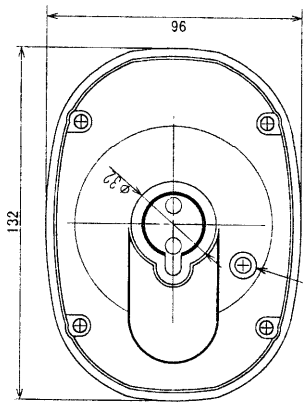
DIMENSION (mm)	TOL. (mm)
$L \leq 50$	± 1.5
$50 < L \leq 100$	± 2.5
$100 < L \leq 500$	± 3

TABLE 1

THREAD DIMENSION (FOR PIPE)
 THREAD TYPE: 1x14UN31B
 THREADS PER INCH (25.4mm) : 14
 PITCH: 1.8143 mm
 THREAD LENGTH: 19 mm OR MORE
 PITCH DIAMETER: 24.17 mm



* USE 1.2 m OR SHORTER WHIP. DO NOT USE LONGER ONE.



TYPE	CABLE LENGTH (m)	PLAG	MASS (kg)
GPA-018	10	TNC-P-3	0.79
GPA-018S	0.2	TNC-J-3	0.35

TABLE 2

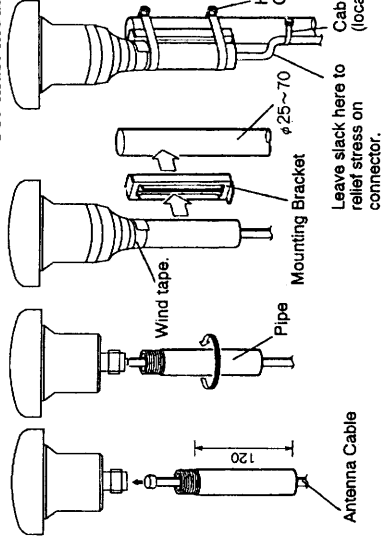
NOTE
 1. TABLE 1 INDICATES TOLERANCE OF DIMENSIONS.

DRAWN	1999	TAKAHASHI
CHECKED	1999	KAWASAKI
APPROVED	1999	KAWASAKI
SCALE	1/2	MASS TABLE 2
DWG. No.	E4385-G01-G	

TITLE	GPA-018/018S
名称	空中線部
外寸図	
NAME	ANTENNA UNIT
OUTLINE DRAWING	

A) Mast mounting

Use mast mounting kit CP20-01111.



NOTES

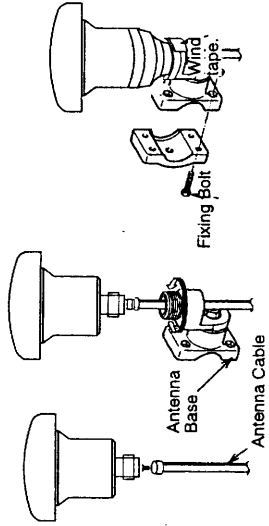
- 1) Fasten pipe to antenna first then fix them to mast.
- 2) When fixing antenna to pipe, turn pipe; not the antenna. Turning the antenna may twist the cable and place stress on connector.

B) Antenna base mounting

Use optional antenna base No.13-QA300 or No.13-QA310.

Inclination	-5° to 33°	32° to 65°	65° to 98°
Right angle antenna base No.13-QA330 (code No. 000-803-239)			
L-type antenna base No.13-QA310 (code No. 000-803-240)			

C) Handrail mounting



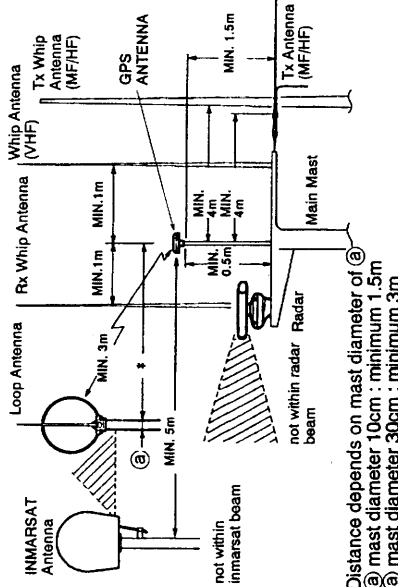
Use handrail mounting base No.13-RCS160 (Code No. 000-861-114, option). The diameter of the handrail may be from $\phi 19\text{mm}$ to $\phi 32\text{mm}$.

NOTES

- 1) Fasten antenna base to antenna first then fix them to handrail.
- 2) When fixing antenna to antenna base, turn antenna base; not the antenna. Turning the antenna may twist the cable and place stress on connector.

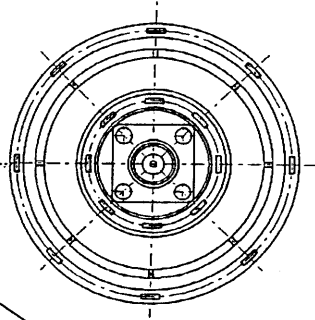
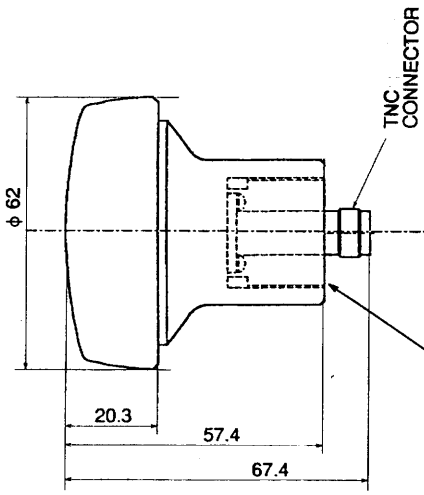
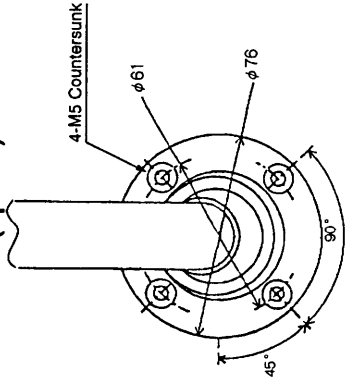
Mounting location

The figure below shows the recommended separation distances from other antennas to avoid mutual interference.



* Distance depends on mast diameter of ϕ
 ① mast diameter 10cm : minimum 1.5m
 ② mast diameter 30cm : minimum 3m

Mounting dimensions of antenna base (option)

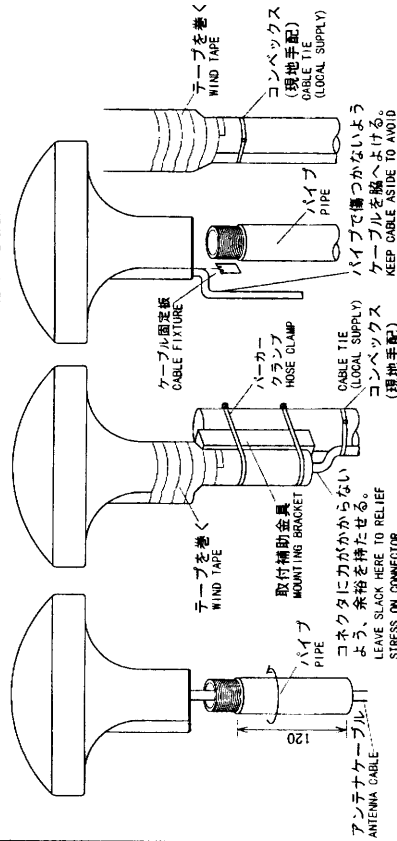


Thread Type	Threads per 25.4 mm (1 Inch)	Pitch	Thread Length	Pitch Diameter
1 X 14UNSB1B	14	1.8143 mm	15.17 mm	24.17 mm

DRAWN	Checked	APPROVED	SCALE	DATE	TYPE	NAME	BLOCK NO.	MODEL
M. S. YAMASAKI	A. KAWAMURA	M. KAWAMURA	0:1 kg		GP-50MK3 PS-8000M2 GP-1600/F GP-8000M2 GP-3100M2 GP-80	GPA-016 空中線部 外寸図 ANTENNA UNIT		ANTENNA UNIT
OUTLINE DRAWING								

A) マストへの取付け MAST MOUNTING

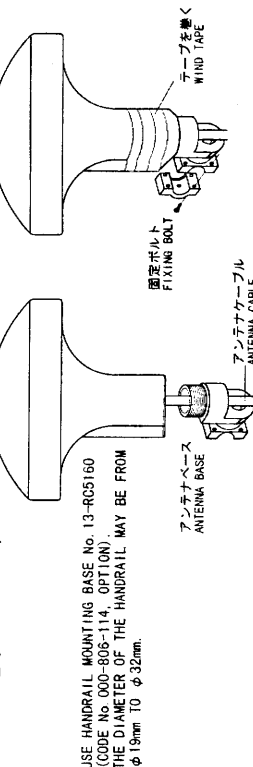
- a) マスト取付套(020-0111)(工事材料)でマストに固定する。
USE MAST MOUNTING KIT (020-0111).
- b) パイプのみを使うとき
USE A PIPE ONLY.



アンテナケーブル ANTENNA CABLE
コネクタに力がかからないよう、余裕を持たせる。
LEAVE SLACK HERE TO RELIEF STRESS ON CONNECTOR.

B) スタンションやバルビットにつけるととき HANDRAIL MOUNTING

レール用アンテナベース No. 13-RC5160 (取付可能レール直径: $\phi 19 \sim \phi 32$)
(コード番号: 000-800-1114)

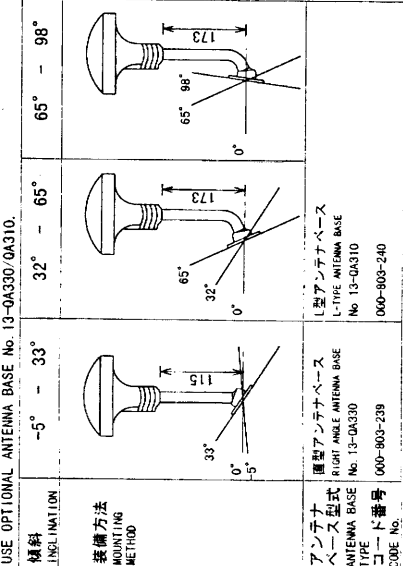


USE HANDRAIL MOUNTING BASE No. 13-RC5160 (CODE No. 000-800-1114, OPTION). THE DIAMETER OF THE HANDRAIL MAY BE FROM $\phi 19$ mm TO $\phi 32$ mm.

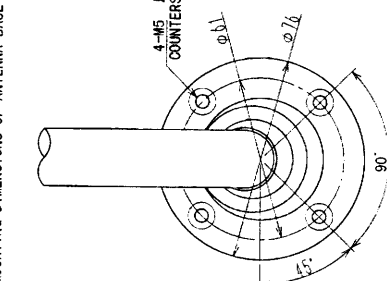
- 注記 1) パイプ(アンテナベース)はアンテナユニットにねじ込んで固定する。
2) アンテナを固定するときはパイプ(アンテナベース)をアンテナにねじ込むこと。アンテナ側をねじるとコネクタ部やケーブルに無理がかかり、故障の原因となる。
- NOTE 1. FASTEN PIPE (ANTENNA BASE) TO ANTENNA UNIT FIRST THEN FIX THEM TO MAST OR HANDRAIL.
2. WHEN FIXING ANTENNA, TURN PIPE OR ANTENNA BASE; NOT THE ANTENNA. TURNING THE ANTENNA MAY TWIST THE CABLE AND PLACE STRESS ON CONNECTOR.

C) 取付ける場所が傾斜しているとき ANTENNA BASE MOUNTING

オプションのアンテナベースを使う。
USE OPTIONAL ANTENNA BASE No. 13-0A330/0A310.

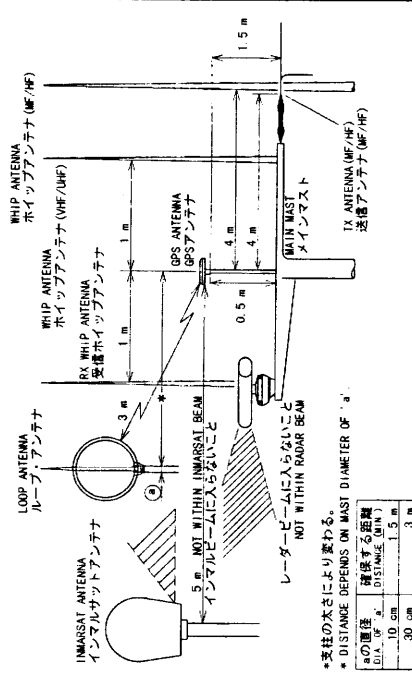


アンテナベース基部 MOUNTING DIMENSIONS OF ANTENNA BASE



取付場所 MOUNTING LOCATION

THE FIGURE BELOW SHOWS THE RECOMMENDED SEPARATION DISTANCES FROM OTHER ANTENNAS TO AVOID MUTUAL INTERFERENCE. 他の機種のアンテナから下の回りの距離以上離す。



※支柱の本径により変わる。
※ DISTANCE DEPENDS ON MAST DIAMETER OF "a".

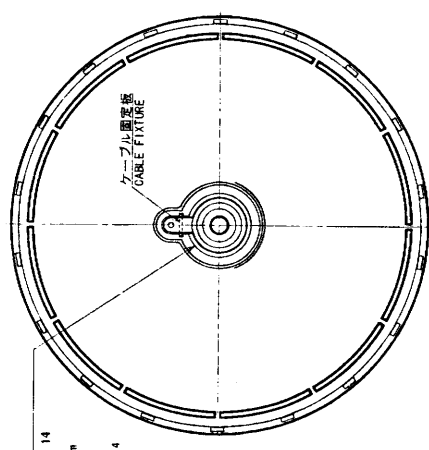
径の距離 DIA. OF "a" DISTANCE (mm)	離すべき距離 3m
10 5m	3m
30 5m	3m

1-14JMS1B
ねじ山径(25.4mmにつき): 14
ピッチ: 1.8143 mm
オネジ有効長さ: 15.17 mm
オネジ有効径: 24.17 mm

ねじ山径(25.4mmにつき): 14
ピッチ: 1.8143 mm
スレッド有効長さ: 15.17 mm
スレッド有効径: 24.17 mm

寸法区分(mm)	DIMENSION	公差(mm)	TOL.
L	50	±1.5	
50 < L ≤ 100		±2.5	
100 < L ≤ 500		±3	

表 1 TABLE 1



注記: 指定外の寸法公差は表 1 による
NOTE: TABLE 1 INDICATES TOLERANCE OF DIMENSIONS.

型式 TYPE	ケーブル長さ(m) CABLE LENGTH	プラグ PLUG	質量(kg) MASS
GPA-019	10	TNC-P-3	1.0
GPA-019S	0.2	TNC-J-3	0.54

表 2 TABLE 2

DRAWN	TITLE
1998.12.17 J. TAMAYAKI	GPA-019/019S
CHECKED	名称
1999.03.09 K. YAMAMOTO	空中線部
APPROVED	外寸図
1999.07.19 K. YAMAMOTO	NAME
SCALE 1/2	ANTENNA UNIT
図 2 表 2	OUTLINE DRAWING
図 No. C4400-601-D	

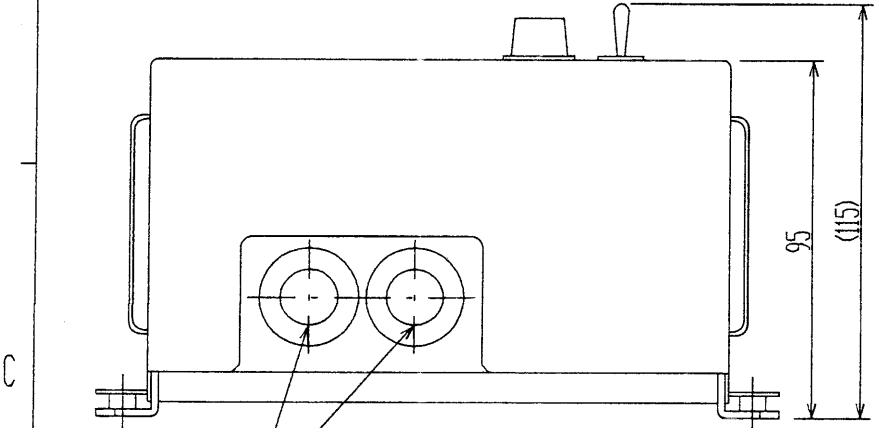
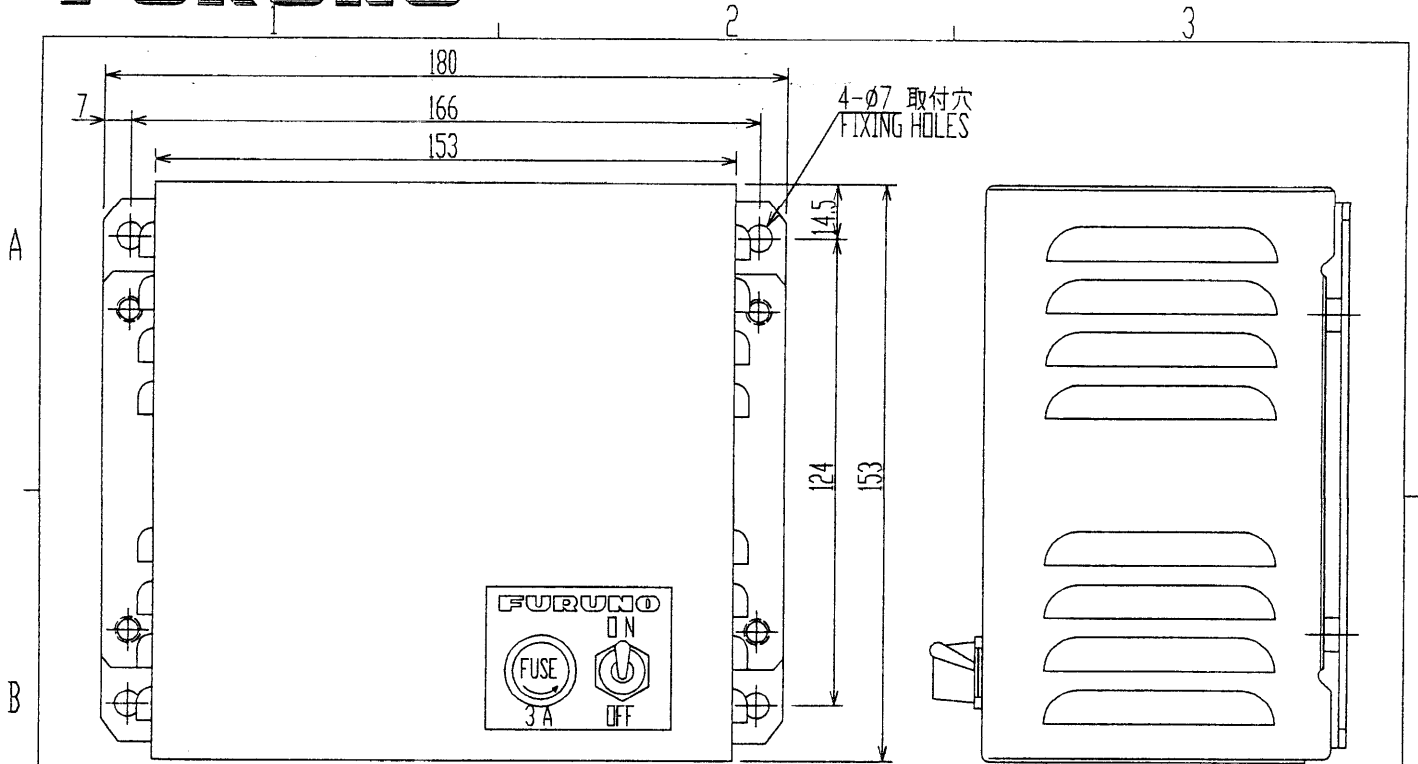


表1 TABLE 1

寸法区分(mm) DIMENSION	公差(mm) TOLERANCE
0 < L ≤ 50	±1.5
50 < L ≤ 100	±2.5
100 < L ≤ 500	±3

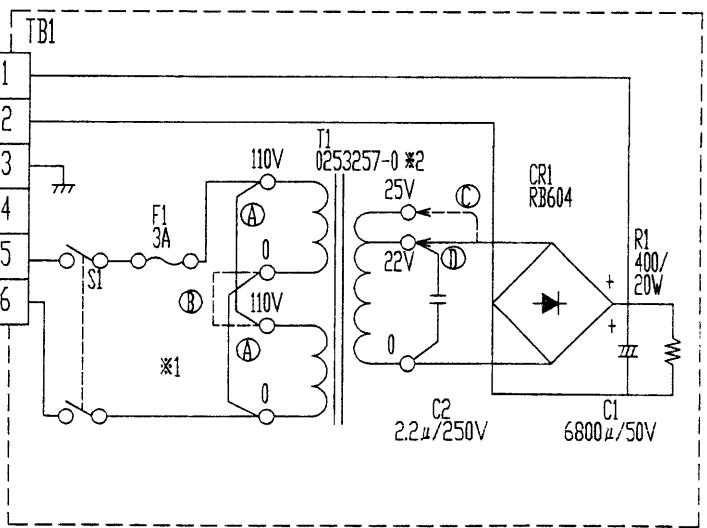
ケーブル導入口
CABLE ENTRY

24VDC
OUTPUT
(2.5A max)

AC INPUT

入力電圧に応じて接続を変更して下さい。
CHANGE TAP CONNECTIONS DEPENDING ON SUPPLY VOLTAGE.

	AC100V	AC110/ 115V	AC220V	AC230V
*1	(A)	(A)	(B)	(B)
*2	(C)	(D)	(D)	(D)



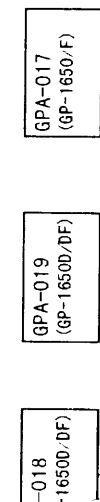
DRAWN Sep. 14 '01 I. YAMASAKI	TITLE PR-62
CHECKED 8-20-01 Y.K.I.	名称 整流器
APPROVED 8-20-01 Y.K.I.	外寸図
SCALE 1/2 MASS 3 ±10% kg	NAME RECTIFIER
DWG.No. C5003-034-E	OUTLINE DRAWING

1 2 3 4

ホイップアンテナ
1.2m WHIP ANTENNA
(OPTION FOR EXPORT)
FAW-1.2

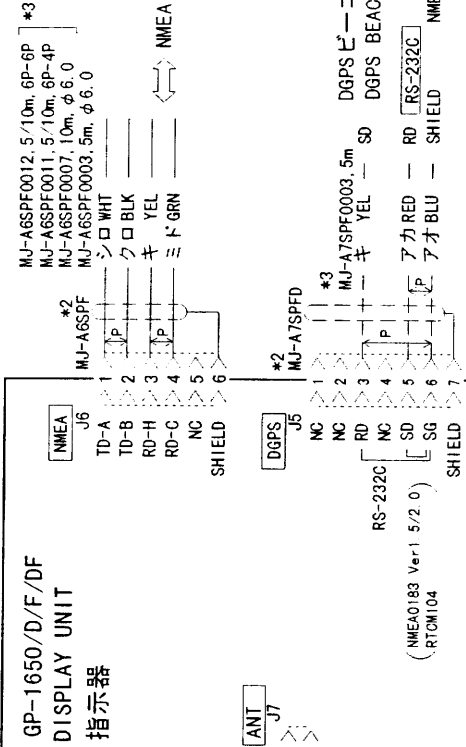
空中線部
ANTENNA UNIT

いずれかを選択
SELECT ONE TYPE



A

GP-1650/D/F/DF
DISPLAY UNIT
指示器

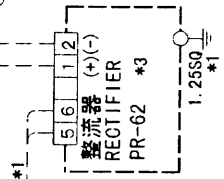


NMEA0183 in RS232C LEVEL *5

B

船内電源
SH1P'S MAINS 02S4094, 3.5m, φ8.0
12-24 VDC
100/110/220V/ 230VAC, 50/60Hz, 1φ

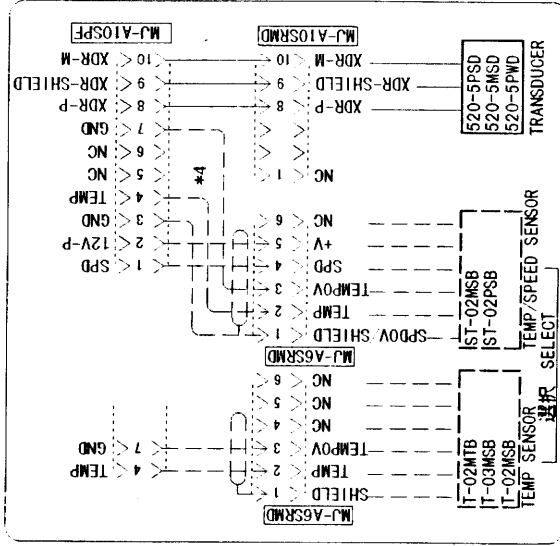
12-24 VDC
J3 (+) 10.8-31.2 VDC
(-) 10.8-31.2 VDC
SHIELD



注記

- * 1) 現地手配
- * 2) コネクタは工場にて取付済み
- * 3) オプション
- * 4) 変換ケーブル組品 (オプション) が必要。
- * 5) オプションのレベル変換器にはオプションのレベル変換器が必要。

C



DRAWN <i>May 17 1997 TAMASAKI</i>	TITLE GP-1650/D/F/DF
CHECKED <i>May 17 1997 KAWADA</i>	名称 カラーGPSプロッタ
APPROVED <i>May 17 1997 KUSUDA</i>	相互結線図
SCALE 1/1000	NAME COLOR GPS PLOTTER
DWG. No. C4394-C01-F	INTERCONNECTION DIAGRAM

- NOTE
- * 1. LOCAL SUPPLY.
 - * 2. FITTED AT FACTORY.
 - * 3. OPTION
 - * 4. THREE-WAY CONVERSION CABLE NEEDED (OPTION).
 - * 5. OPTIONAL LEVEL CONVERTER REQUIRED FOR CURRENT LOOP OR RS422 OUTPUT.

